

**Radio Engineering Industries**  
**HD5 Series**  
**Mobile Digital Video Recorders**

**Hardware User Manual**  
**Hardware Installation Manual**



---

# HD5 Series Mobile DVR

---

## Table of Contents

<b>List of Figures</b> .....	<b>4</b>
<b>Introduction</b> .....	<b>6</b>
<b>Features</b> .....	<b>6</b>
<b>Specifications</b> .....	<b>7</b>
<b>System Overview</b> .....	<b>9</b>
Front and Back Panels .....	10
Live View.....	11
Initial Set Up.....	11
<b>Removable HDD and SD Card</b> .....	<b>12</b>
DVR Loading and Unloading .....	12
SD Card Loading and Unloading.....	13
HDD Record Times .....	14
Long Term Storage .....	14
<b>Installation</b> .....	<b>15</b>
External Record Indicator / Event Mark Button Harness .....	16
GPS Antenna Module Harness .....	17
Vehicle Sensor Options Harness.....	18
Vehicle Sensor Options Harness Vehicle Connections .....	19
On-Screen Information with Vehicle Sensor Options Harness .....	20
Accelerometer Module Harness.....	21
Physical Mounting Requirements .....	22
L Bracket Mounting.....	22
Security Cover Mounting .....	23
Camera Placement .....	23
System Start-Up.....	24
System Shut-Down .....	24
<b>Playback Options</b> .....	<b>25</b>
TV Video Outputs.....	25
Removable HDD and SD Card.....	25
PC Network Connection .....	25
REI Toolkit .....	27
REI Toolkit Dongle Connection.....	28
Connecting to an Android™.....	28
Connecting to an iPhone™.....	28
Auto Local/Manual Remote.....	29
Logging In.....	29
SD Card Function .....	30
Logging Out .....	30
<b>Menu Configuration</b> .....	<b>32</b>
Main Menu Page.....	32

---

## HD5 Series Mobile DVR

---

Setup Menu .....	32
System Setup Menu .....	33
ID Menu.....	33
Time & Date Menu .....	34
Start Up Menu.....	35
Faults Menu .....	36
Password Menu.....	37
Video Setup .....	38
Camera Menu.....	39
IP and Port Setup Menu.....	40
Network Setup Menu.....	41
Alarm Menu.....	41
SD Menu.....	42
Sub-Stream Menu .....	43
Image Menu .....	43
Motion Menu .....	44
OSD Menu.....	45
Input Setup.....	46
Speed Menu .....	46
Inputs Menu.....	47
Accel Menu.....	49
GPS Port Menu.....	50
Network Setup .....	51
WAN/LAN Setup .....	51
Server.....	52
WIFI Menu .....	53
Cellular Network .....	54
Route.....	54
Info.....	55
Camera.....	55
Inputs .....	55
Alarms .....	56
System .....	56
WAN/Cell.....	57
WIFI.....	57
Versions .....	58
Logs .....	58
Maintenance.....	59
Firmware.....	59
Config Menu.....	59
Storage .....	59
Live .....	60
Info Button.....	60
Settings button .....	60
Channel Selection .....	61
Play Back .....	61
Video (Time/Date Search).....	61
Alarm.....	62
<b>FCC Statement .....</b>	<b>63</b>

---

# HD5 Series Mobile DVR

---

## List of Figures

Figure 1: HD5 Series MDVR System Diagram.....	9
Figure 2: Front Panel Layout .....	10
Figure 3: Rear Panel Layout .....	11
Figure 4: Removable Hard Drive Module .....	12
Figure 5: Removable SD Card.....	13
Figure 6: Estimator for HDD Record Times.....	14
Figure 7: System Wiring - Power and Camera Cables .....	15
Figure 8: External Record Indicator/Event Mark Button Harness Connection .....	16
Figure 9: GPS Antenna Module Harness Connection .....	17
Figure 10: Vehicle Sensor Options Harness Connection.....	18
Figure 11: Accelerometer Module Harness Connection.....	21
Figure 12: 3 Axis Inertia Sensor Directions .....	21
Figure 13: L Bracket Mounting .....	22
Figure 14: DVR Dimensions .....	22
Figure 15: Security Cover Mounting .....	23
Figure 16: Connecting to the DVR with a Computer through the Ethernet Connection..	25
Figure 17: Initial DVR Window .....	29
Figure 18: Login Window.....	30
Figure 19: Logout Window.....	31
Figure 20: Main Menu .....	32
Figure 21: Setup Menu.....	32
Figure 22: System Setup Options .....	33
Figure 23: ID Menu .....	33
Figure 24: Time & Date.....	34
Figure 25: Custom DST Triggers .....	35
Figure 26: Start Up Menu in Ignition Mode .....	35
Figure 27: Record Schedule Menu .....	36
Figure 28: Faults .....	36
Figure 29: Password.....	37
Figure 30: Video Setup.....	38
Figure 31: Camera – Camera Setup .....	39
Figure 32: Custom Record Settings .....	39
Figure 33: IPC Setup Pop-up Window .....	40
Figure 34: Individual Channel Network Setup .....	41
Figure 35: Alarm Setup.....	41
Figure 36: SD Setup.....	42
Figure 37: Sub-Stream Setup .....	43
Figure 38: Image Setup.....	43
Figure 39: Motion Setup .....	44
Figure 40: Motion Setup - Set Grid .....	45
Figure 41: OSD Setup.....	45

---

## HD5 Series Mobile DVR

---

Figure 42: Input Setup .....	46
Figure 43: Speed Setup .....	46
Figure 44: Inputs Setup.....	47
Figure 45: Input Setup - Custom.....	48
Figure 46: Accelerometer Setup .....	49
Figure 47: Accel Alarm .....	49
Figure 48: Accelerometer Threshold .....	50
Figure 49: GPS Port .....	50
Figure 50: Network Setup.....	51
Figure 51: General Network Setup .....	51
Figure 52: Server.....	52
Figure 53: WIFI Setup .....	53
Figure 54: Cellular Setup .....	54
Figure 55: Route Setup .....	54
Figure 56: Info Menu .....	55
Figure 57: Camera Tab .....	55
Figure 58: Inputs Tab.....	55
Figure 59: Alarms Tab.....	56
Figure 60: System Tab.....	56
Figure 61: WAN/Cell Tab .....	57
Figure 62: WIFI Tab .....	57
Figure 63: Versions Tab.....	58
Figure 64: Logs Tab.....	58
Figure 65: Logs – Search Result.....	58
Figure 66: Upgrade Firmware.....	59
Figure 67: Export Configuration.....	59
Figure 68: Storage Tab.....	59
Figure 69: Live Menu .....	60
Figure 70: Channel Bar.....	60
Figure 71: Sample Info Data Table.....	60
Figure 72: Channel Selection Buttons .....	61
Figure 73: Playback Menu .....	61
Figure 74: Video Tab - Time/Date Search for Date .....	61
Figure 75: Alarm Tab - Alarm Search .....	62

---

# HD5 Series Mobile DVR

---

## Introduction

This manual is intended to provide information required for proper installation, initial setup, and explanation of the individual programming options pertaining to the HD5 Series Mobile DVR surveillance system. For assistance or to answer any questions call:

**24 HOUR SERVICE HOT LINE**  
**USA & CANADA**  
**1-877-726-4617 Toll Free**  
**1-402-339-2200**

The HD5 is a cost effective, embedded mobile DVR solution supporting up to 6/12 analog camera inputs. This system features a unique compact rugged design engineered to meet the demands of harsh mobile environments. The HD5 mobile DVR features the latest technologies including H.264/MPEG-4 Advanced Video Compression, dual streaming technology, and all solid-state construction.

## Features

- High Definition (1080p) on All Channels
- Ultra HD (4k) Channels 9-12
- GPS
- 4G Cellular (optional)
- Fast 802.11n Wi-Fi
- Optional Panic Button
- Full-Frame rate up to 30fps/Channel
- H.264 Triple Streaming
- Optional Accelerometer
- Up to 2TB Hard Drive or optional Solid State Hard Drive
- Up to 256GB SD Card (optional)
- Optional Lockbox
- Extruded aluminum chassis
- Fanless design

---

# HD5 Series Mobile DVR

---

## **Specifications**

Power: 8 to 32 Volts DC, <2A operating (excludes cameras, accessories)

Dimensions: Without brackets: 7.4" x 3.2" x 9.5"; with brackets: 9.1" x 4.0" x 9.5" (max)

Weight: 8.6 lbs. (3.90 kg) with mounting brackets

Standby Current: < 2mA

Operating Temperature: -40°+160°F continuous operation

Operating Humidity: 10% - 95%, non-condensing

## **Video Recording**

Video Inputs: Up to 12 Channels

Video Standards: NTSC, AHD, ONVIF, REI

Resolution: Up to 1080P Channels 1-8; Up to UHD (4K) Channels 9-12

Frame Rate: Up to 30 fps per channel

Bit Rate: 40 Mbps

Compression: H.264 Triple stream encoding/ recording – high quality recording + efficient network video streaming

Audio Inputs: 12

Total Channels: 12

## **Storage**

Hard Drive: Removable hard disk drive module with USB 3.0 interface, integrated shock and vibration dampening, and heater

Expandable Storage: eSATA port for external storage expansion (external HDD) – up to 16TB of total internal/external storage

SD Card: SD slot for simultaneous (mirror) or alarm video recording

## **Communication Module**

Easily Upgradeable Communication Module: Field or factory installed removable communication module

WIFI (internal): Optional 802.11a/b/g/n 2.4Ghz/5Ghz Wi-Fi (Wi-Fi models only)

Cellular (internal): Optional 3G/4G modem for cellular connectivity

GPS (internal): Optional internal or external GPS receiver

---

## HD5 Series Mobile DVR

---

### **Inputs/Outputs**

USB ports: Two front panel USB ports for mouse and video backup, firmware update, configuration, and debugging (log files, etc.)

WAN Ports: Rear panel WAN (Ethernet) port for connection to external 3G/4G cellular router and for connection to REI and non-REI in-vehicle systems

LAN Ports (IPC, etc.): Front panel LAN port for local DVR configuration, camera adjustment, IP camera setup, etc.

Front Panel Audio/Video Port: Front panel composite audio/video outputs for local DVR configuration, camera setup, etc. using a USB mouse

Vehicle Interface (J1939): Dual SAE J1939 250kbps/500kbps interface for connection to in-vehicle networks, multiplex systems, etc.

Accessory Port (RS485): For connection to optional REI peripherals, including accelerometer, output modules, display modules, RFID, etc., and non REI devices

GPS/Status Port (RS232): Optional external (RS232) GPS receiver Optional GPS/Status output (RS232) for interface to third-party AVL systems

Sensor Inputs: Eight sensor inputs for detection of vehicle signals (brakes, turn signals, etc.)



# HD5 Series Mobile DVR

## System Overview

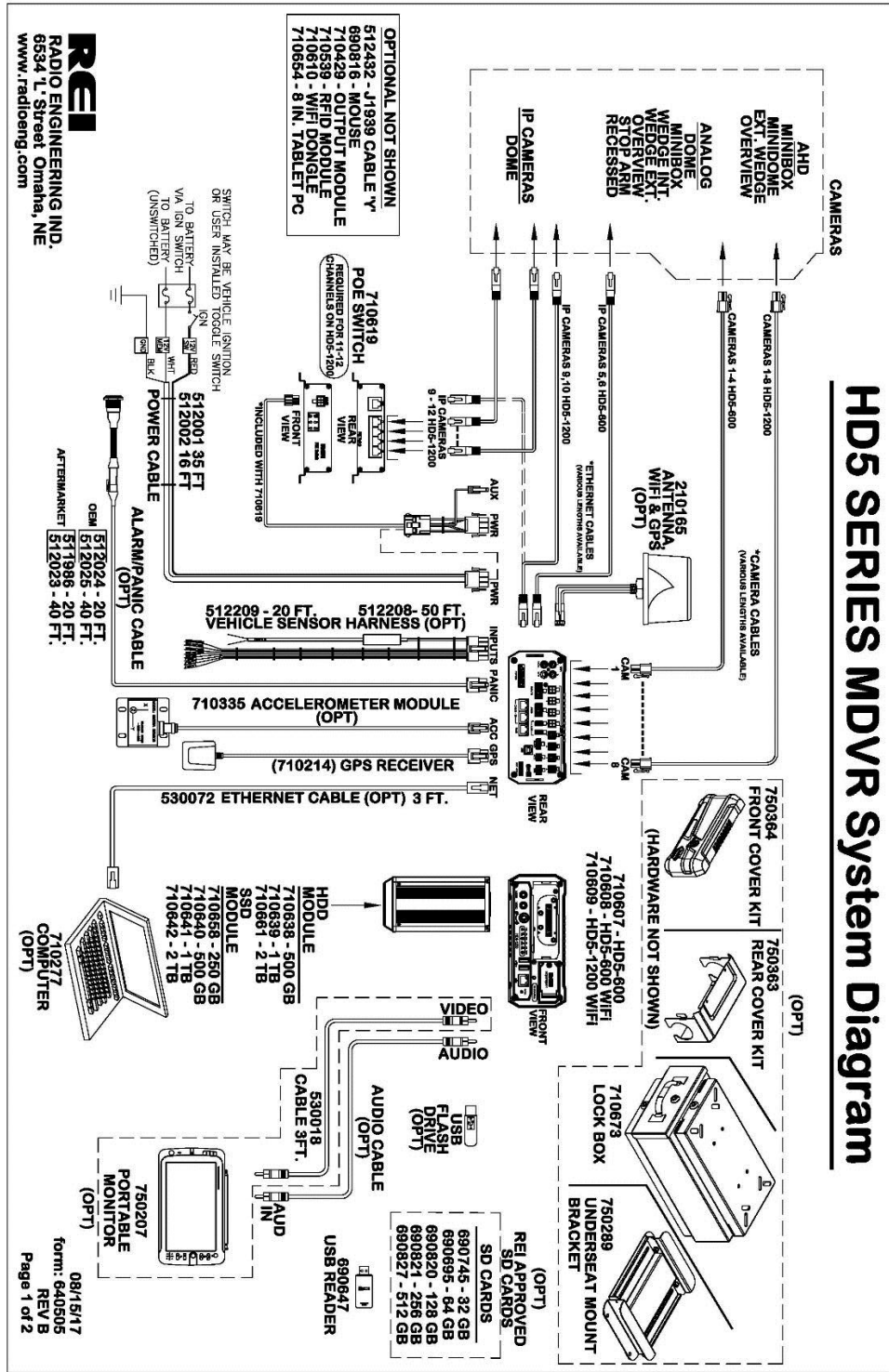

Figure 1: HD5 Series MDVR System Diagram

---

# HD5 Series Mobile DVR

---

## Front and Back Panels

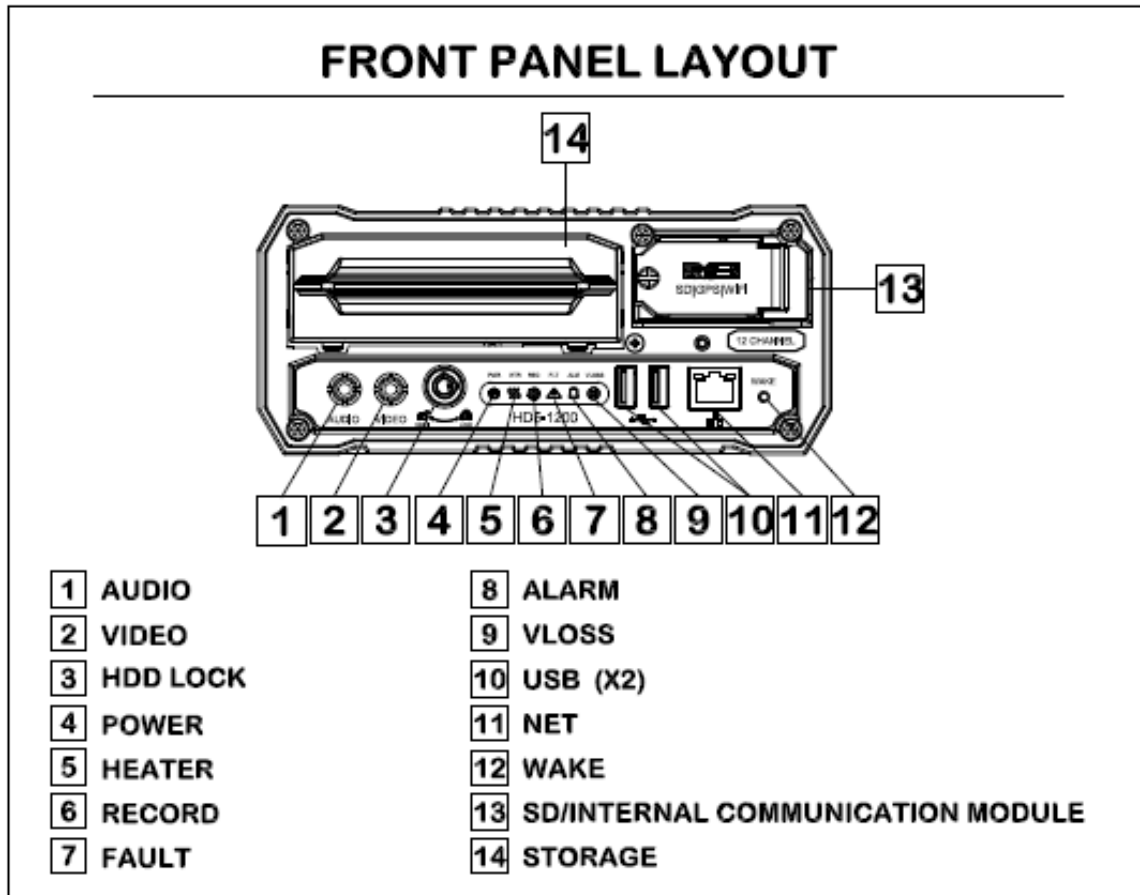

Figure 2: Front Panel Layout

---

# HD5 Series Mobile DVR

---

## REAR PANEL LAYOUT

---

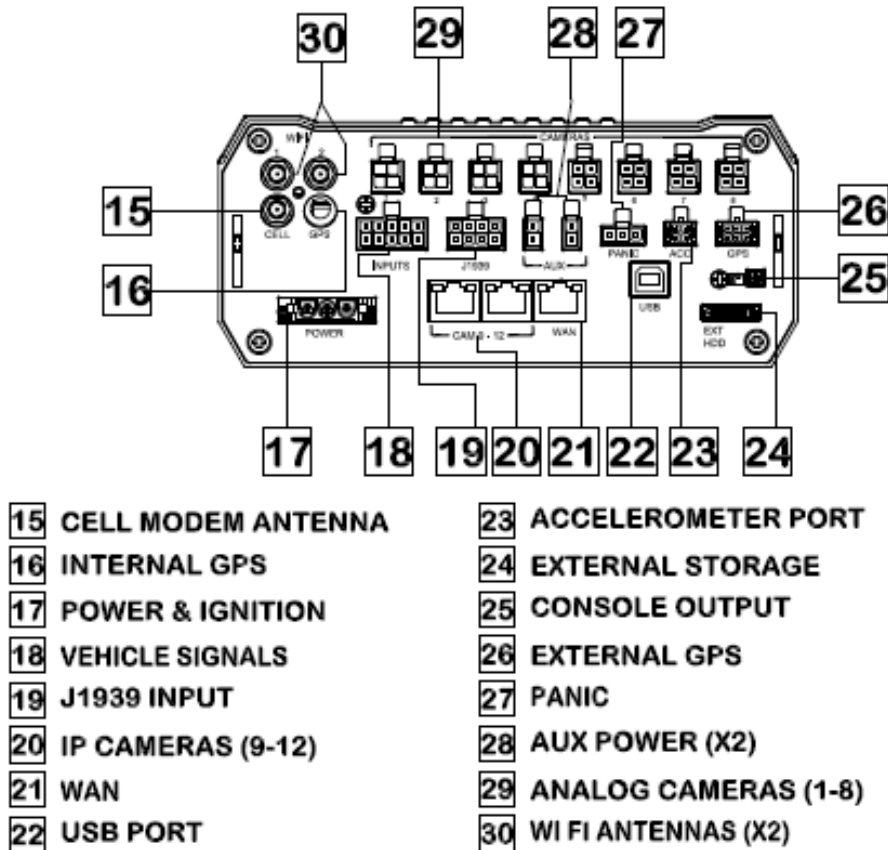

Figure 3: Rear Panel Layout

### Live View

The default view in live view mode using a video monitor connected to the front of the 6/12 channel DVRs displays all channels in matrix view. Left clicking a USB mouse while in matrix view displays the video from that window into full screen. Left clicking the mouse returns the display to matrix view.

### Initial Set Up

The HD5 Series Mobile DVR system will operate prior to any user setup with the default settings. However, it may not show the correct time and date (factory set to Central Standard Time). To set the correct date and time, and program the system operation to your requirements, refer to the *Menu Configuration* section of this manual.

When accessing the menu, it is necessary to connect a video monitor to the video jack on the front or back of the unit. REI recommends using its battery-powered color LCD monitor P/N 750207.

### Removable HDD and SD Card

#### DVR Loading and Unloading

**Inserting HDD:** Turn the HDD key to the unlocked and off position. Slide the HDD into the DVR and press firmly to make sure it is all the way in. Turn the HDD key to the locked and on position.

**Removing HDD:** Turn the HDD key to the unlocked and off position. Grab the handle on the HDD and carefully pull it out.

**Note:** The HD5 Series Mobile DVR HD5 series DVR will function even in the absence of a HDD. Without HDD, DVR will power on and allow the user to configure the settings, but it will not record any videos unless the user loads the HDD and locks the HDD key.

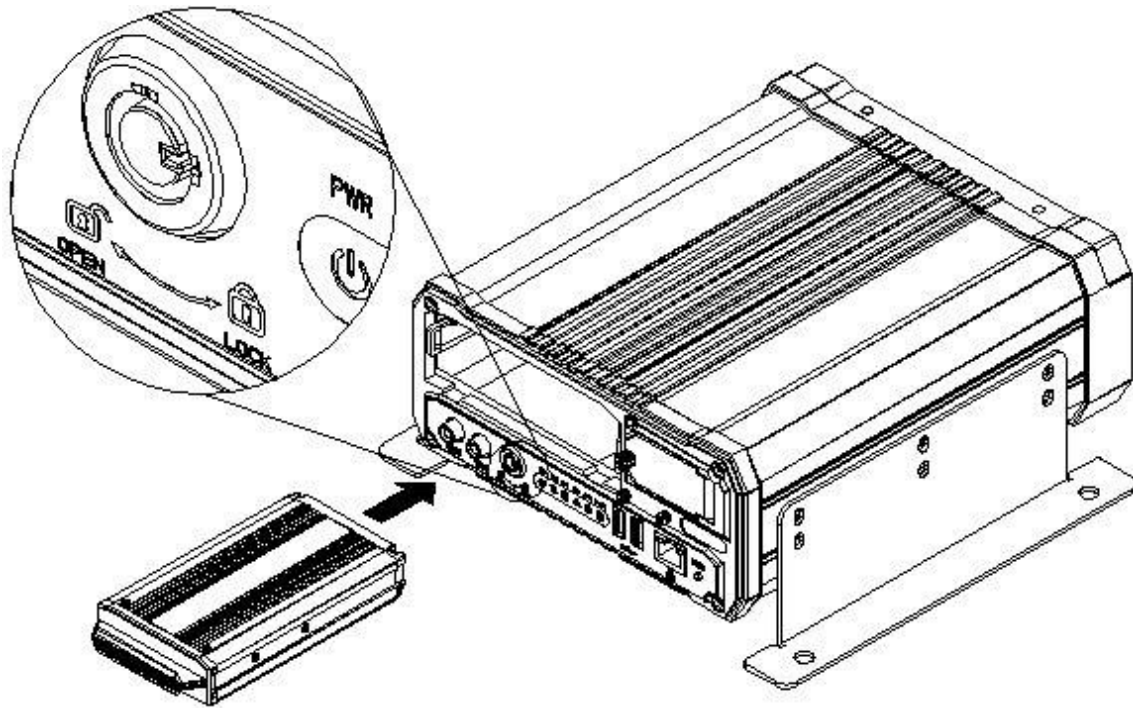

Figure 4: Removable Hard Drive Module

---

## HD5 Series Mobile DVR

---

### SD Card Loading and Unloading

**Inserting SD Card:** Open the access door and insert the SD card all the way in until it locks in place.

**Removing SD Card:** Push on the SD card all the way in, then release to eject the SD card.

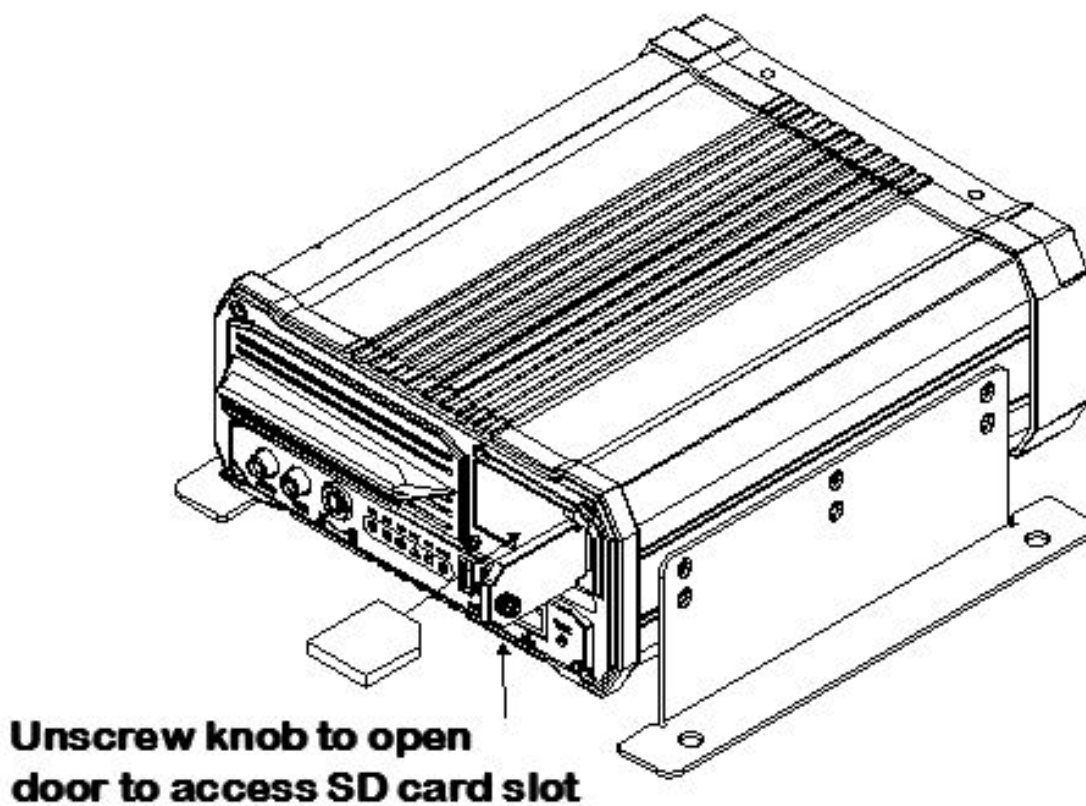

Figure 5: Removable SD Card

---

# HD5 Series Mobile DVR

---

## HDD Record Times

To help estimate record times please visit our website [www.radioeng.info/rte/hd5.zip](http://www.radioeng.info/rte/hd5.zip).

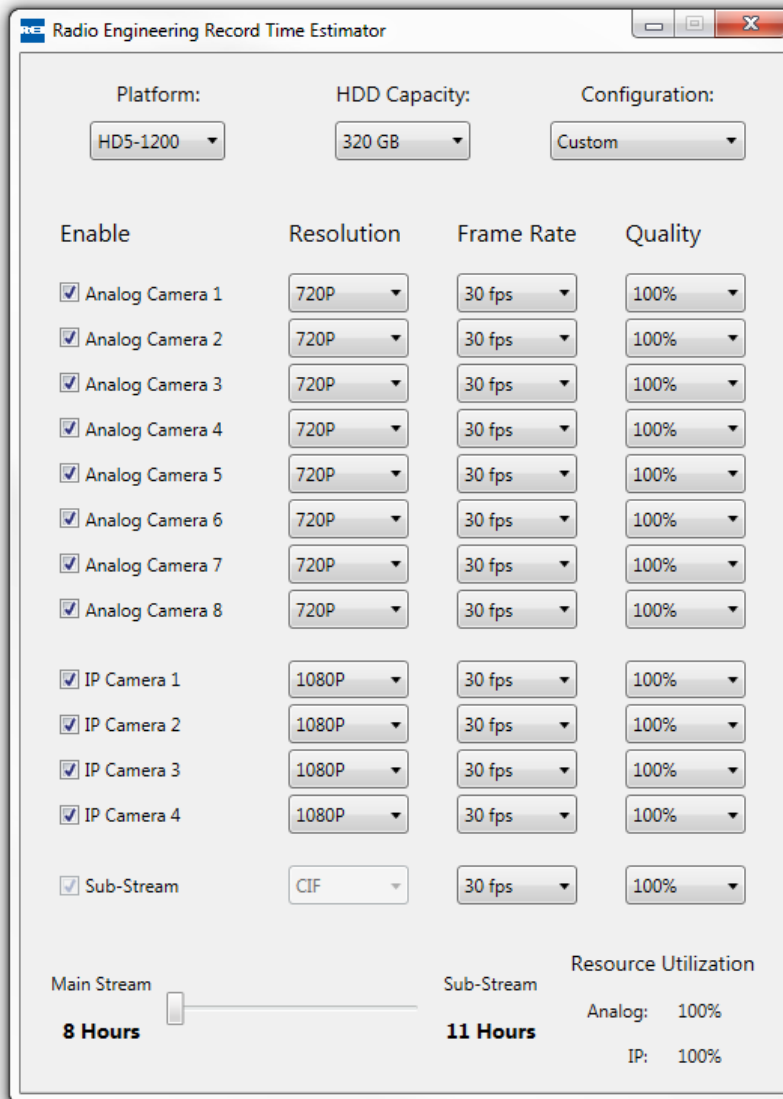

Figure 6: Estimator for HDD Record Times

## Long Term Storage

The HD5 Series Mobile DVR systems draw very little current in stand-by mode. If the systems are installed, but not used for an extended period of time (i.e., longer than two weeks) it is recommended that the power be disconnected from the DVR to avoid draining the vehicle battery. The DVR internal clock will hold the time and date for up to 10 years sitting on a shelf, and the daylight-saving time functions will resume upon re-initialization when power is applied.

---

# HD5 Series Mobile DVR

---

## Installation

### WARNING

***DISCONNECT VEHICLE BATTERY VOLTAGE BEFORE INSTALLING  
System WIRING***

### WARNING

***DISCONNECT POWER TO THE DVR BEFORE JUMP STARTING  
VEHICLE***

## System Wiring

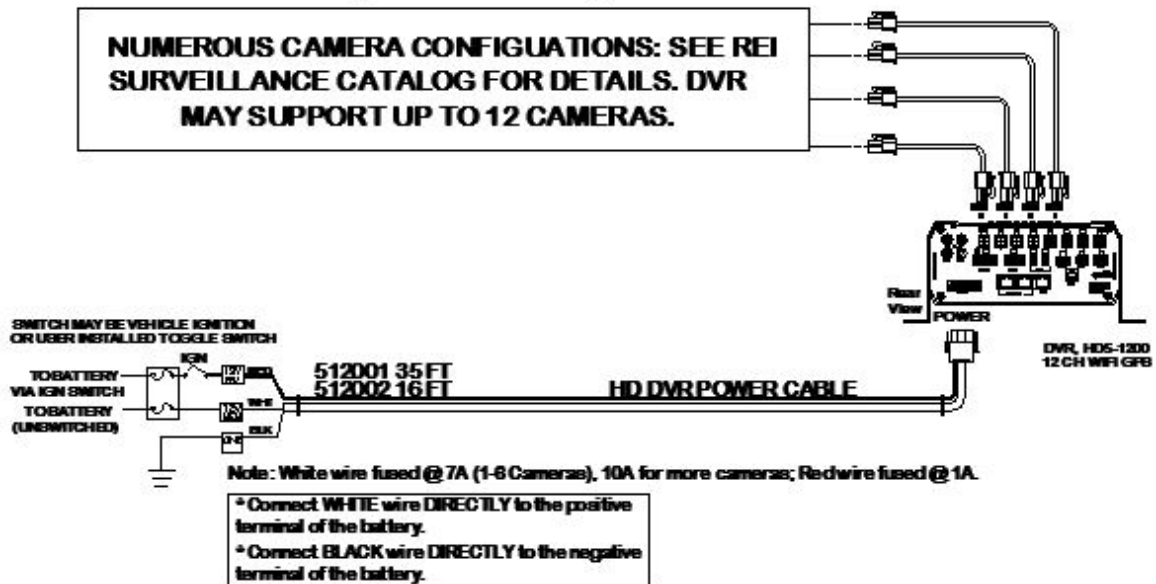

Figure 7: System Wiring - Power and Camera Cables

---

## HD5 Series Mobile DVR

---

### External Record Indicator / Event Mark Button Harness

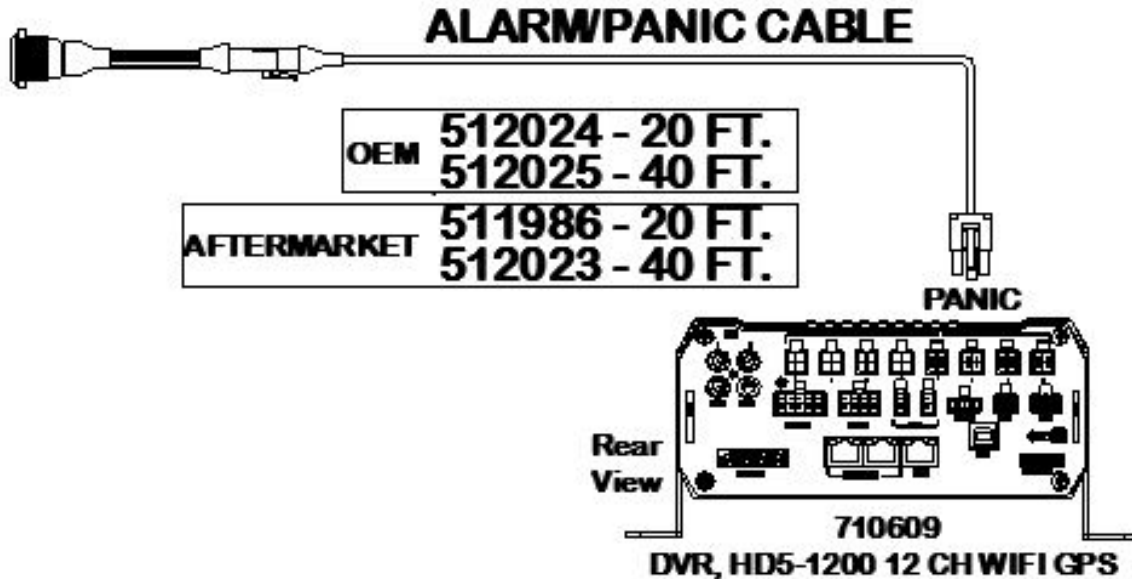

Figure 8: External Record Indicator/Event Mark Button Harness Connection

The optional external record indicator / event mark button harnesses (Panic Button) are available with two different types of switches, OEM and aftermarket. The OEM switch is rectangular and fits into a standard size dashboard knockout. The aftermarket switch is round, for easier installation in vehicles without spare switch knockouts. Both styles of switches plug into the same port on the back of the DVR.



---

## HD5 Series Mobile DVR

---

### GPS Antenna Module Harness

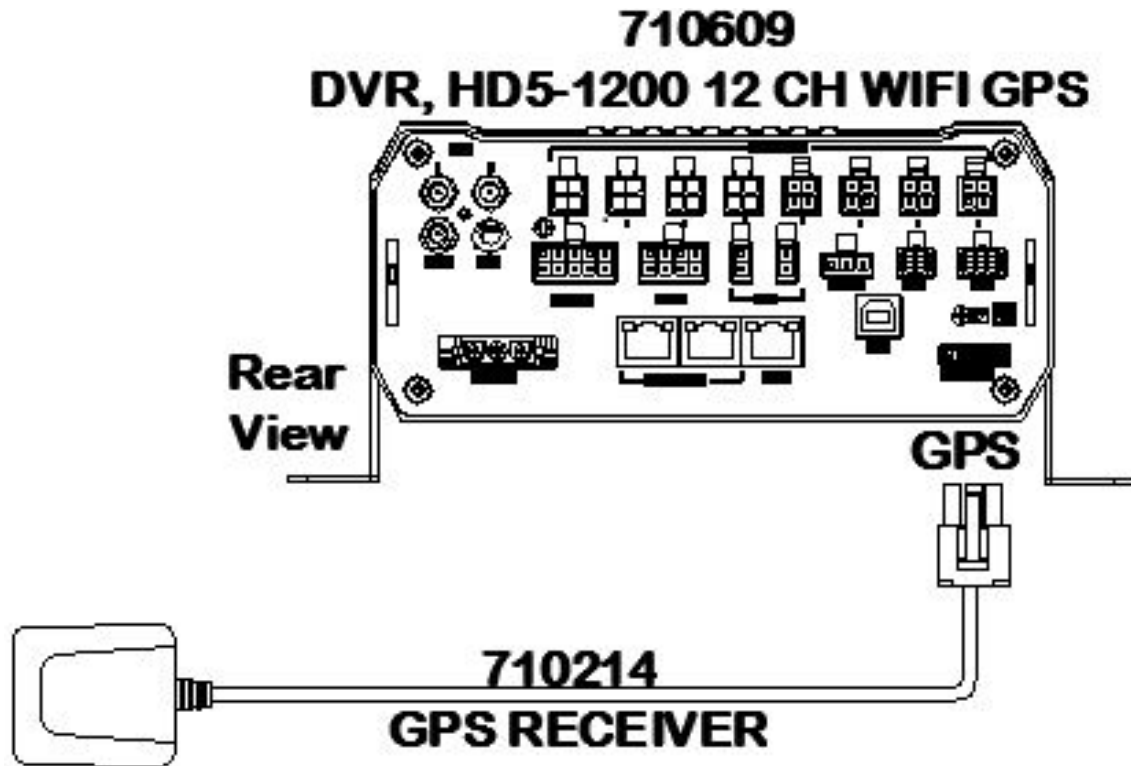

Figure 9: GPS Antenna Module Harness Connection

The optional DVR GPS antenna module harness plugs into the back of the DVR. This module will track up to 12 satellites at a time while providing one-second navigation updates at low power consumption.

The GPS antenna module is housed in a black, water-resistant case and designed to withstand rugged operating conditions. Information provided to the DVR system includes longitude, latitude, speed, heading, date, and time. Internal memory backup allows the GPS antenna module to retain critical data such as satellite orbital parameters, last position, date, and time to reduce valid data acquisition time.

The 710214 GPS antenna is used for extremely accurate requirements, if the DVR is used with a lot based Wi-Fi network, it could be more cost effective to use the combination Wi-Fi/GPS antenna that comes with the higher end DVRs.

# HD5 Series Mobile DVR

## Vehicle Sensor Options Harness

### Vehicle Sensor Options Harness

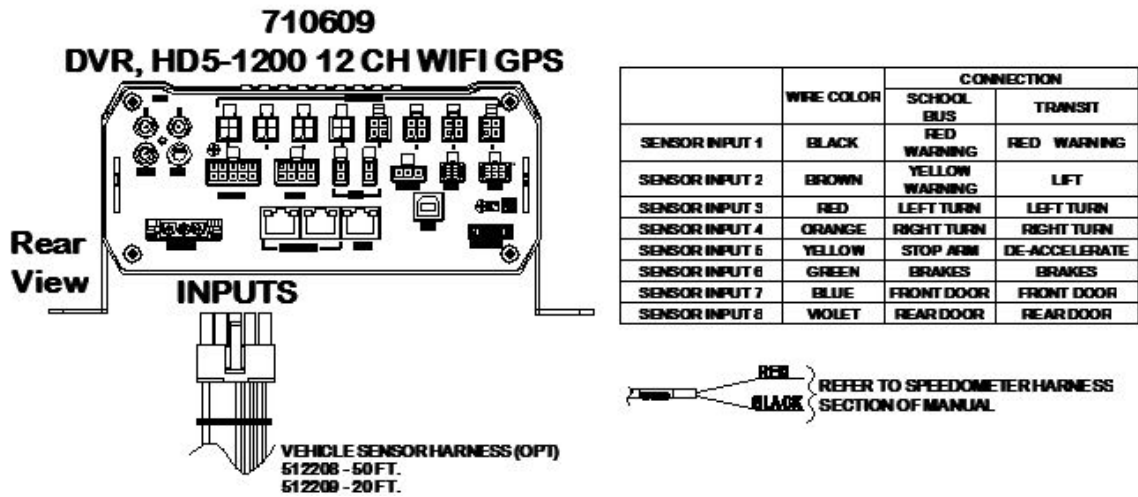

Figure 10: Vehicle Sensor Options Harness Connection

The Vehicle Sensor Options harness connects to various locations in the vehicle to provide on-screen information regarding vehicle performance. Vehicles have different sets of signals that can be monitored. Two levels of pre-defined on-screen displays are available to the installer: SCHOOL BUS and TRANSIT.

The default SCHOOL BUS monitored points in the vehicle are:

- Red warning lamp operation
- Amber warning lamp operation
- Left turn signal
- Right turn signal
- Stop arm lamp operation
- Brake activation
- Front Door
- Rear Door

The default TRANSIT monitored points in the vehicle are:

- Auxiliary 1
- Auxiliary 2
- Left turn signal
- Right turn signal
- Warning lamp operation (de-acceleration lights)
- Brake activation
- Front door switch operation
- Back door switch operation
- Optional point with Auxiliary

Aux inputs are user-defined and may be used to monitor points such as wheelchair lifts, inertia sensors, etc.

---

## HD5 Series Mobile DVR

---

### **Vehicle Sensor Options Harness Vehicle Connections**

(Shown as School Bus)

<b>WIRE COLOR</b>	<b>WIRE DESCRIPTION</b>
BLACK	RED WARNING LAMP
BROWN	YELLOW WARNING LAMP
RED	LEFT TURN SIGNAL
ORANGE	RIGHT TURN SIGNAL
YELLOW	STOP ARM
GREEN	BRAKES
BLUE	FRONT DOOR
VIOLET	REAR DOOR

#### **Yellow Warning Lamps**

Connect the BROWN wire to the Yellow lamp output of the Warning Lamp Flasher.

#### **Red Warning Lamps**

Connect the BLACK wire to the Red lamp output of the Warning Lamp Flasher.

#### **Stop Arm Lamps**

Connect the YELLOW wire to the switched side of the stop arm lamp.

#### **Brake Lamp**

Connect the GREEN wire to the switched side of one brake lamp.

#### **Turn Signals**

Connect the RED and ORANGE wires to the left and right turn signal lamps.

#### **Front and Back Doors**

Connect the BLUE and VIOLET wires to the switched side of the door switches.

---

## HD5 Series Mobile DVR

---

### On-Screen Information with Vehicle Sensor Options Harness

The HD5 Series Mobile DVR Surveillance system, when equipped with the HD5 Series Mobile DVR Option Harness, will display information on-screen in the Installers Mode when the monitored switches on the vehicle are activated and signals are applied to the monitored sensors.

<b>ACTIVE SWITCH OR SIGNAL</b>	<b>ON-SCREEN DISPLAY</b>
BRAKE APPLIED	<b>BR</b>
STOP ARM DEPLOYED	<b>SA</b>
YELLOW WARNING LAMPS On	<b>YW</b>
RED WARNING LAMPS On	<b>RW</b>
LEFT TURN SIGNAL On	<b>LT</b>
RIGHT TURN SIGNAL On	<b>RT</b>
FRONT DOOR OPEN	<b>FD</b>
REAR DOOR OPEN	<b>RD</b>
SPEEDOMETER (SEE NOTE 1)	<b>XX MPH</b>

NOTE 1:

The XXs represent the vehicle speed (i.e. 35).

---

# HD5 Series Mobile DVR

---

## Accelerometer Module Harness

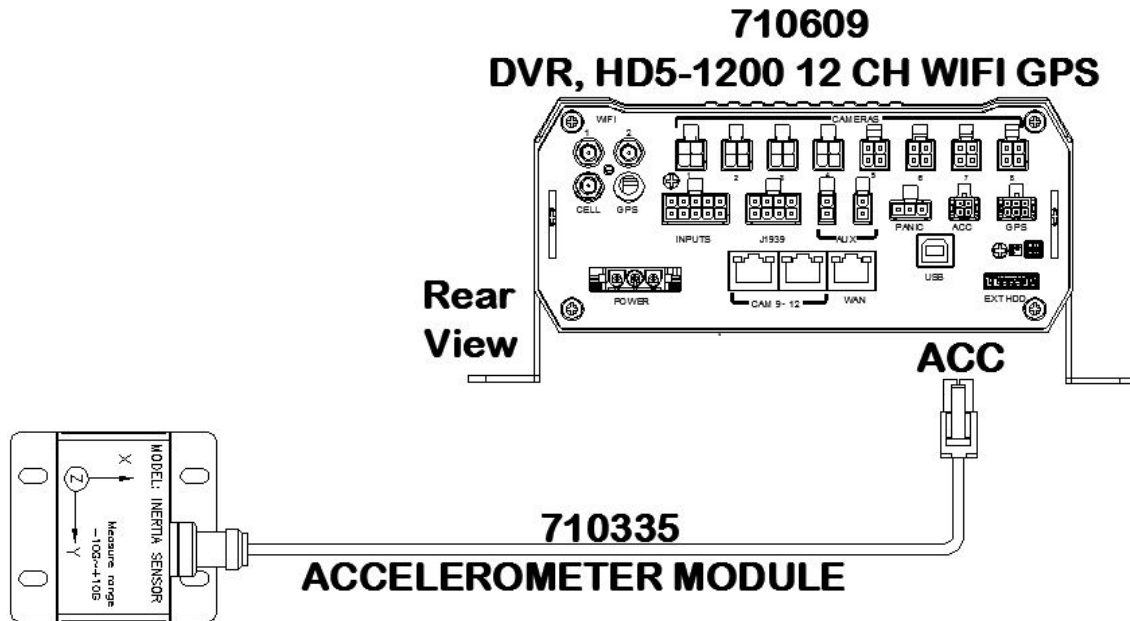

Figure 11: Accelerometer Module Harness Connection

The optional external Accelerometer, or Inertia Sensor, must be hard-mounted to the vehicle floor, frame, or some other non-dampened part of the vehicle. If external dampening is used for the DVR, hard-mounting the accelerometer will prevent the accelerometer readings from being compromised.

To properly install the Accelerometer Module, the user must align the device with the picture on top of the module. The 'X' axis is drawn from the back to the front of the bus, the 'Y' axis is drawn from the side of the bus to the other side of the bus, and the 'Z' axis is drawn from the bottom to the top of the bus. After the device has been properly aligned, the Accelerometer Module must be calibrated.

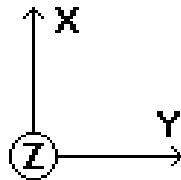

Figure 12: 3 Axis Inertia Sensor Directions

---

# HD5 Series Mobile DVR

---

## Physical Mounting Requirements

### L Bracket Mounting

The DVR has two L-brackets along the side of the unit to allow easy mounting. This type of installation is recommended for vehicles that have a secured compartment, such as a radio box, where the DVR is protected from tampering.

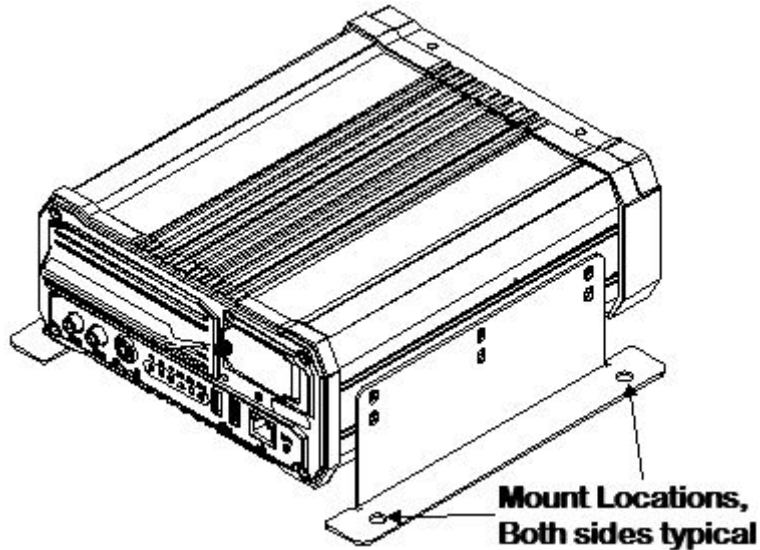

Figure 13: L Bracket Mounting

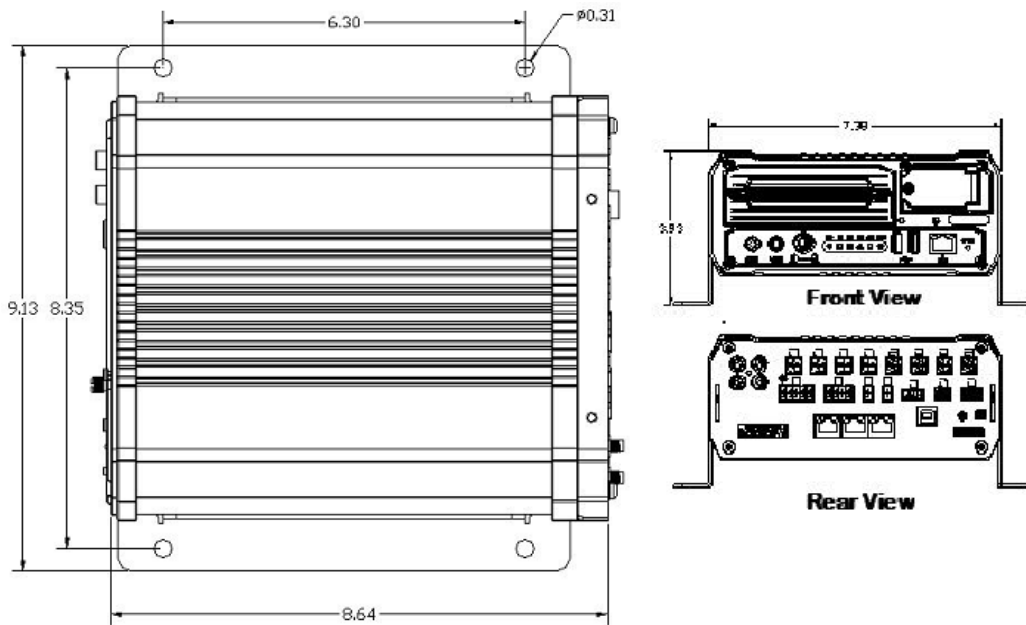

Figure 14: DVR Dimensions

---

## HD5 Series Mobile DVR

---

### Security Cover Mounting

There may be installations that require the front and back of the DVR to be enclosed in a protective enclosure. Security covers can be installed to protect the front and back of the DVR.

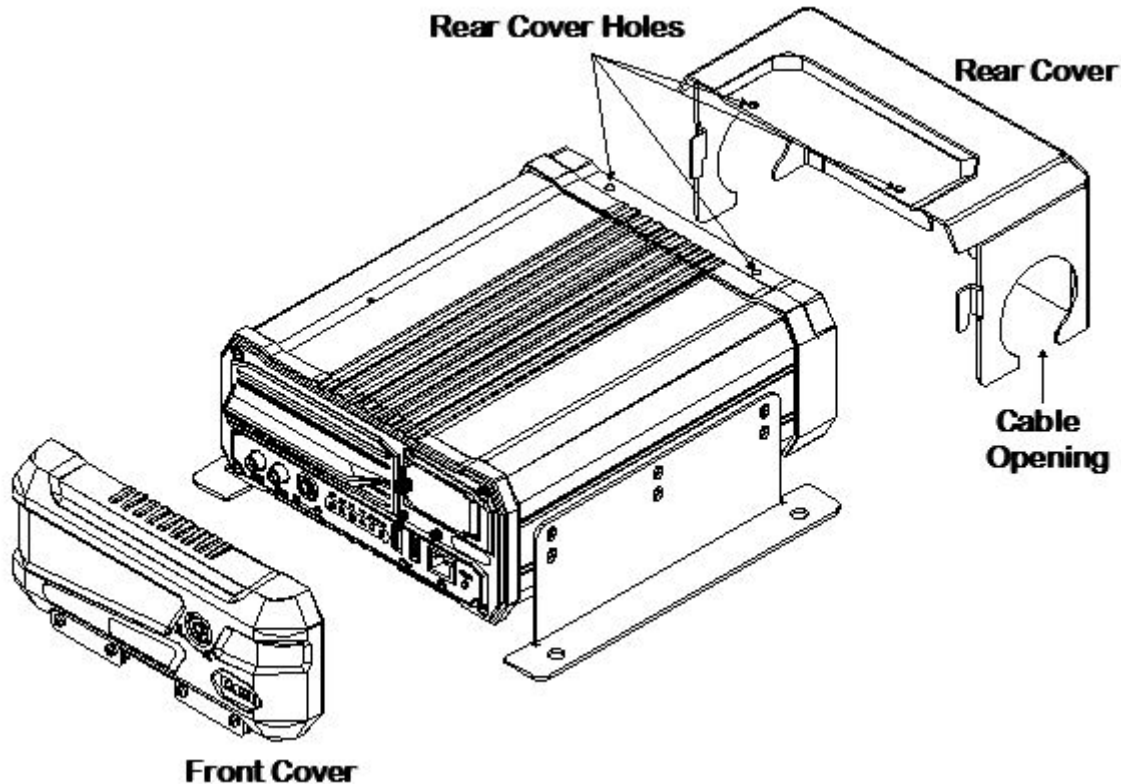

Figure 15: Security Cover Mounting

### **IMPORTANT:**

Check local, state, and federal guidelines as to modification of the existing structures within the vehicle.

### Camera Placement

The HD5 Series Mobile DVR cameras can be mounted anywhere in the vehicle, unless the mount is unstable or the cameras vibrate excessively. Use outdoor cameras for exterior placement.

---

## HD5 Series Mobile DVR

---

### **System Start-Up**

To start the recording process, start the vehicle. Upon turning the system switch ON, the HD5 Series Mobile DVR will commence recording.

### **System Shut-Down**

To stop the recording process, off the vehicle. If the OFF DELAY option is enabled, the HD5 Series Mobile DVR will continue to record for the prescribed number of minutes. When the off-delay expires, the camera and HD5 Series Mobile DVR shut off. If a download delay is used, the DVR will stay active after any off delay expires for network access to the hard drive, but will not record any new video in this mode.



---

## HD5 Series Mobile DVR

---

### Playback Options

The various ways to view the recorded videos: through the TV Video Outputs, through the Removable Hard Drive Module, SD card, through the PC Network Connection, and with a mobile device such as a cell phone or a tablet.

### *TV Video Outputs*

Using a TV Monitor and a USB mouse, the user can access recorded video files by Date and Time or by Event. After selecting the appropriate file, the user can review the video using Play, Stop, Pause, Fast Forward, Fast Rewind, Slow Forward, Slow Rewind, Frame Forward, and Frame Reverse.

### Removable HDD and SD Card

Using the REI VMS PC Software, the user can access the files by connecting HDD or SD Card to the computer.

### PC Network Connection

Using the REI VMS PC Software, the user can access the files by connecting the computer to the DVR Front Panel Ethernet port, as shown below.

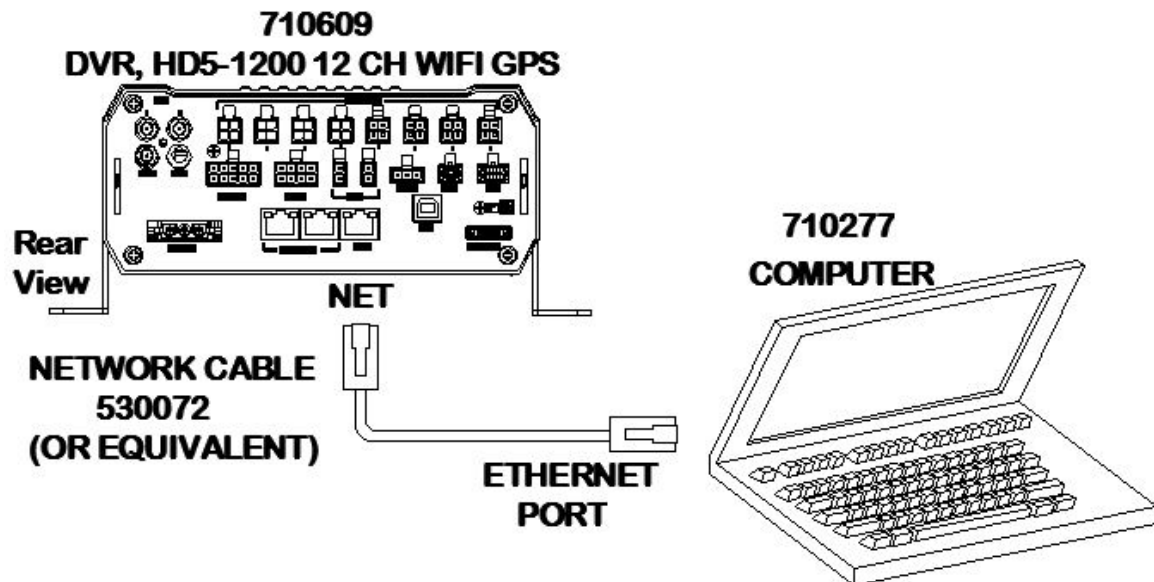

Figure 16: Connecting to the DVR with a Computer through the Ethernet Connection

---

## HD5 Series Mobile DVR

---

Default DVR LAN Settings:

IP Address: 192.168.200.200

Net Mask: 255.255.255.0

Username: admin

Password: 11111111

To access the DVR from a computer, the TCP/IP network settings on the computer need to be configured to match the settings in the DVR to insure both devices are in the same network. For example, when DVR network is set to default as above, the TCP/IP on the computer needs to be set as follows:

IP Address: 192.168.200.x (x being 1-255 but different from DVR IP address)

Net Mask: 255.255.255.0 (DVR Net Mask)

Gateway: 192.168.200.254 (DVR Gateway) - optional

---

## HD5 Series Mobile DVR

---

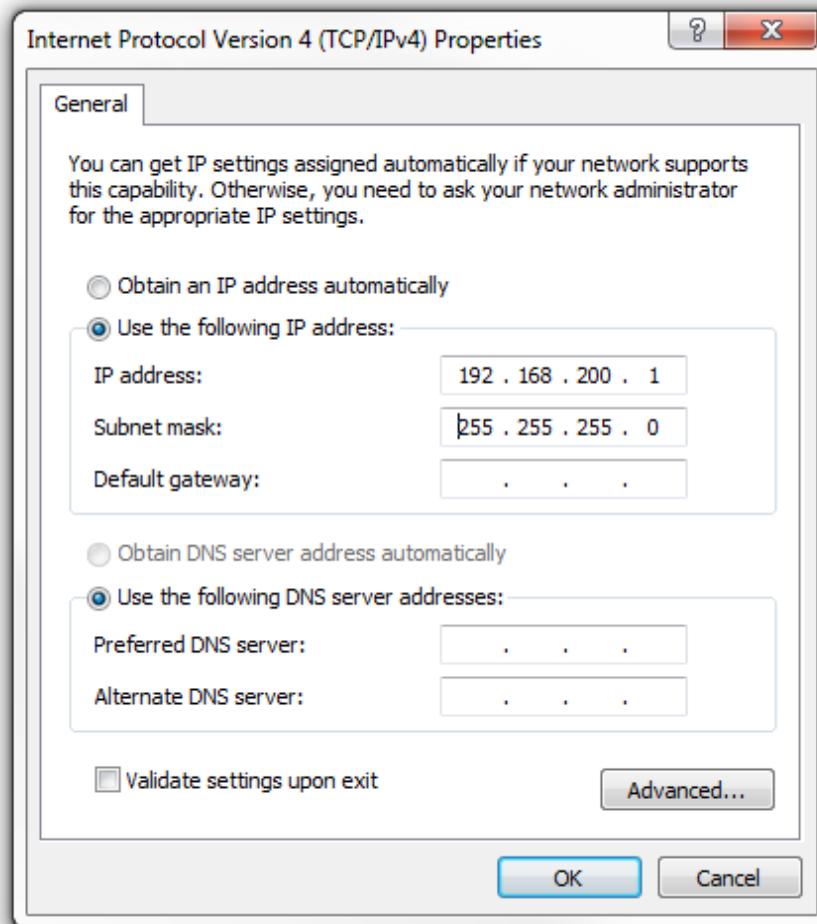

Once the computer is set up, open Internet Explorer and enter the IP address of the DVR in the web address bar. In some cases, the web browser may display a prompt requesting the installation of add-on software in order to access the DVR Web UI. Before displaying the Web UI, the web browser will display a prompt requesting the username and password for the DVR. After entering the username and password, the web browser will open the Web UI. Refer to the Web UI section for more information.

### REI Toolkit

The use of a REI Toolkit Dongle enables a wireless connection from the DVR to a hand held device (iPhone™, Android™, or touch pad) in the event Wi-Fi is not available.

The REI DVR Toolkit must be downloaded on the hand held device used in conjunction with the REI Toolkit Dongle and the DVR.

To download the REI DVR Toolkit, complete the following instructions:

If using an Android™ device:

---

## HD5 Series Mobile DVR

---

- From the Google Play Store search for the REI DVR Toolkit by typing REI DVR Toolkit in the Search window in the Apps section and click the Search icon.
- Click on the REI DVR Toolkit icon  to open the app
- Click the Install button

If using an Apple device (iPhone™):

- Enter REI DVR Toolkit in the search window on the Apple application store and click search
- Click Get
- Click Install
- Sign In with your Apple ID and follow the installation prompts

### REI Toolkit Dongle Connection

Before establishing connectivity with your Android™ or iPhone™, plug the USB cable from the REI Toolkit Dongle into the DVR.

When the REI Toolkit Dongle is connected to the DVR, a blue ‘Power’ lamp will illuminate to indicate the device is operating.

**Note:** If the REI Toolkit Dongle is unavailable it is possible, on Wi-Fi enabled HD5 series DVRs, it is possible to obtain a Wi-Fi connection by pressing and holding the Wake button for two seconds.

### Connecting to an Android™



To connect to the REI Dongle, go into ‘Settings’ and choose ‘Network & Internet,’ and then ‘Wi-Fi.’

From the list of Wi-Fi links, locate the appropriate Wi-Fi  link and attempt to make a Wi-Fi connection. It is normal to see the message ‘Connected, no Internet’ indicating there is no Internet connection.

Close the application.

From the home screen of your Android™ device, select the REI DVR Toolkit icon  that will open the initial REI DVR window.

### Connecting to an iPhone™

When using an iPhone™, make sure the device is plugged in the DVR (for example REI-009). To verify the Wi-Fi connection to the DVR is available on your iPhone™, select the Settings icon  and then select the Wi-Fi icon  to open the list of available Wi-Fi networks under ‘CHOOSE A NETWORK’. At this point, the connection for the example DVR, REI-009, should appear on the list of Wi-Fi networks. From the home screen of your iPhone™ select the REI DVR Toolkit icon  to open the REI DVR window. Once

---

## HD5 Series Mobile DVR

---

the REI DVR Toolkit has been opened, the initial REI DVR window will appear on the iPhone™ with the name of the DVR connection (the example REI-009 shown on the Initial DVR window). At this point, the REI DVR Toolkit is available for use.

### Auto Local/Manual Remote

On the initial screen, **Auto Local** is selected by default. This setting means the DVR wireless hardware switched over to access point mode and is connecting locally on the bus. If set to **Manual Remote**, the access point is based on IP forwarding to connect to lot-based Wi-Fi to enable a connection to any of the active buses remotely without having to actually be aboard the bus.



Figure 17: Initial DVR Window

### Logging In

Touch the name of the DVR, (REI-009 for example) and a Login prompt will appear as shown below.

---

## HD5 Series Mobile DVR

---

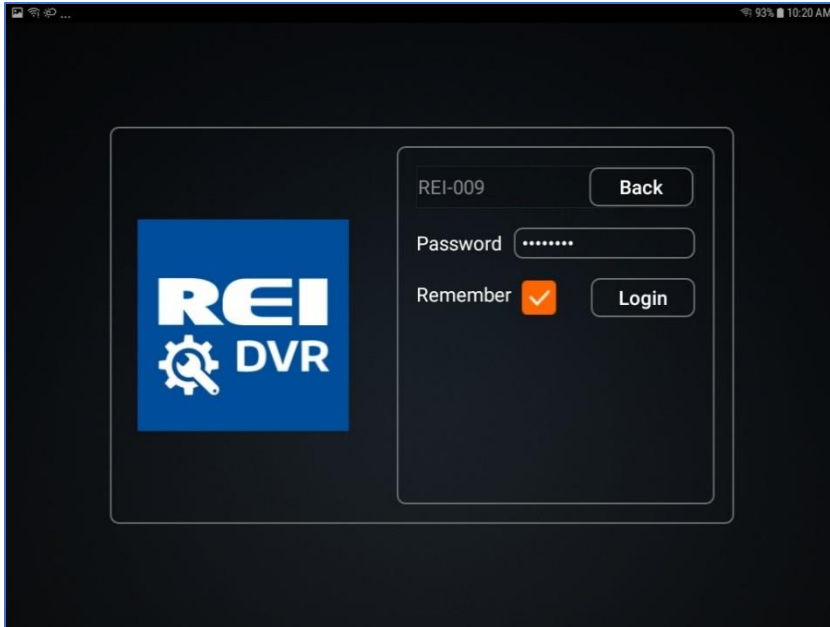

Figure 18: Login Window

By default, the password is 11111111. The **Remember** box may already be checked. If not, enter the password and click **Login**. The initial window will appear where the user can begin to access the REI ARMOR DVR firmware.



### SD Card Function

On the side of the REI Toolkit Dongle is a slot that serves as a Secure Digital (SD) card reader.

When the red SD lamp is active, it indicates a SD card is successfully loaded in the SD card slot and operational.

The primary purpose of using the SD card function is system upgrades. A system upgrade can be performed by downloading the upgrade content from the SD card to the DVR. The card operates similar to a flash drive and the system-upgrade content from the SD card can be displayed on your hand held device and the system upgrade steps can be performed.

### Logging Out

When using an Android™ device, selecting  will open the **Logout** prompt and choosing 'Yes' will end the Wi-Fi connection. Selecting  will also allow an exit from Live View.

When using an iPhone™, selecting  will allow an exit from Live View. To logout using an iPhone™, press the Home button and disconnect the REI Toolkit Dongle from the DVR.

---

## HD5 Series Mobile DVR

---

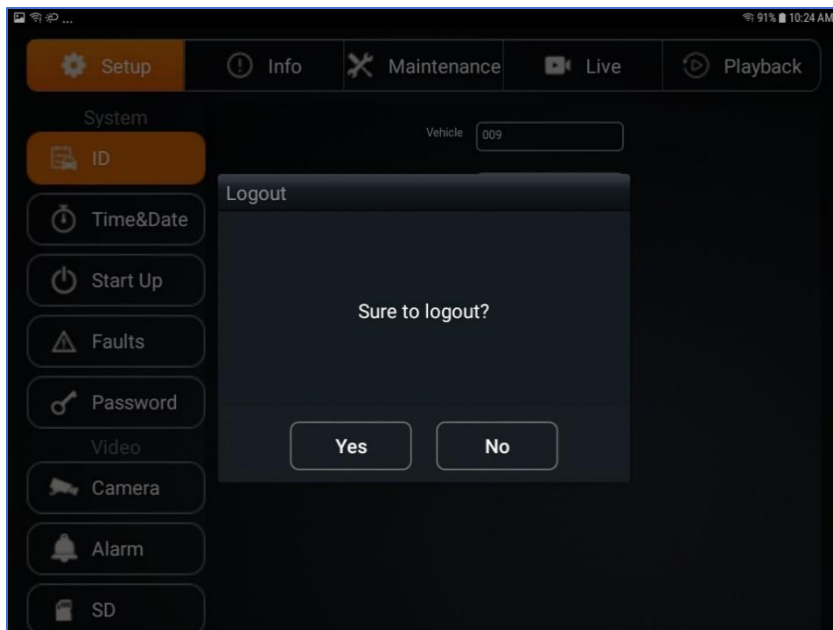

Figure 19: Logout Window

For more information about using the REI Toolkit, refer to the *REI Toolkit Quick Guide*.

---

# HD5 Series Mobile DVR

---

## Menu Configuration

### Main Menu Page

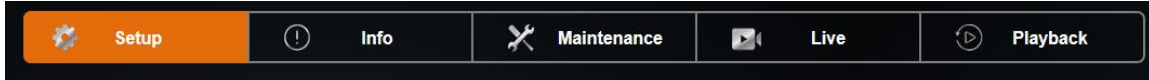

Figure 20: Main Menu

The DVR Main Menu can be accessed by using any standard USB mouse and video monitor. For more convenient usage, REI offers its hand-held USB trackball mouse; P/N 690816. The user can access recorded videos and customize the settings on the DVR.

The Main Menu is comprised of five user tabs: Setup, Info, Maintenance, Live, and Playback.

### Setup Menu

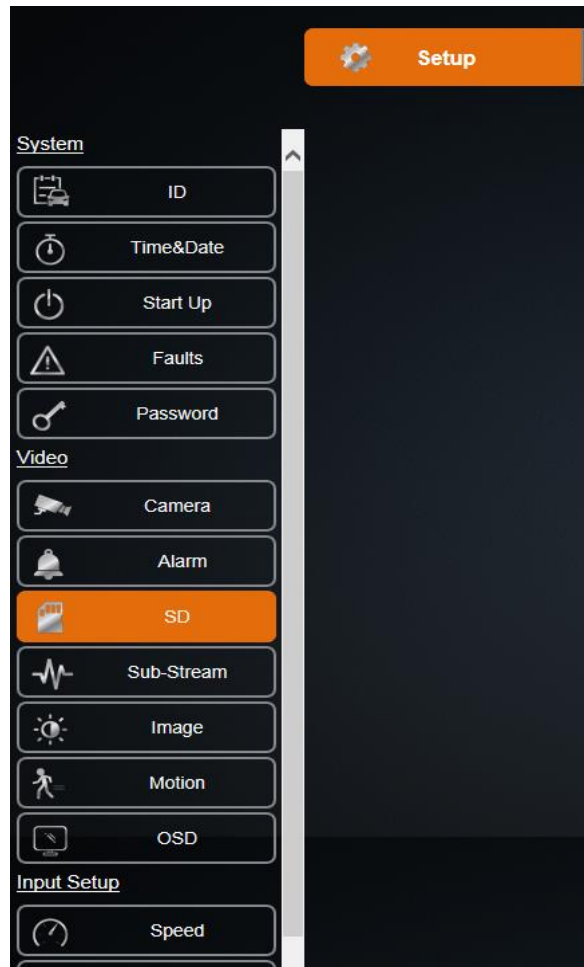

Figure 21: Setup Menu



---

## HD5 Series Mobile DVR

---

The Setup section of the Menu is subdivided into four main categories listed in the left column of the window: System, Video, Input Setup, and Network.

### System Setup Menu



Figure 22: System Setup Options

System: The System section of the Setup Sub-Menu is subdivided into five subcategories: ID, Time & Date, Start Up, Faults and Password. The user can give the vehicle a name, set the time and date, set when the DVR starts recording, set fault indicators, fault beepers, external record indicator, stand-by mode display, and set a password for the DVR.

### ID Menu

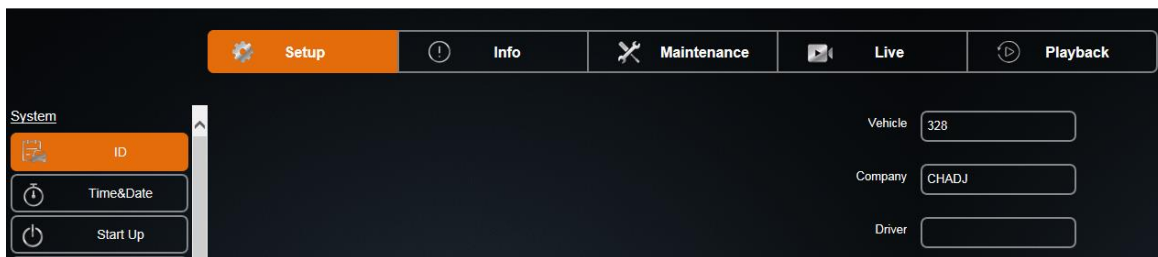

Figure 23: ID Menu

ID Menu allows the user to enter the Vehicle, Company, and Driver name.

Vehicle: Allows custom information to identify the DVRs, such as bus number.

Company: Allows the user to enter company name of the bus service.

Driver: Allows user to enter a driver's name.

---

# HD5 Series Mobile DVR

---

## Time & Date Menu

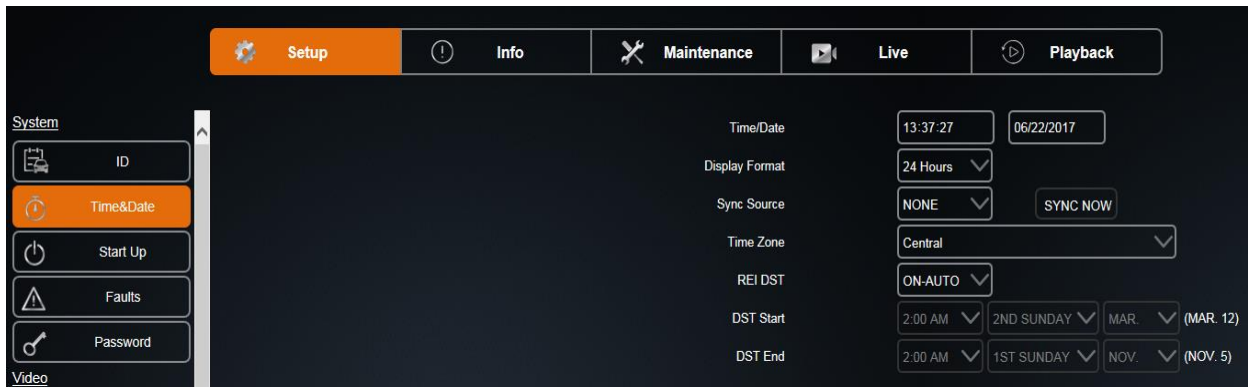

Figure 24: Time & Date

Time & Date menu allows the user to configure options for setting the Date and the Time. All REI DVRs use high accuracy, extended temperature range real time clocks with 10-year internal battery backup for consistent and reliable time keeping over the life of the DVR system.

Time/Date: Displays the current date and time, allowing the user to change the date and time.

Display Format: Allows the user to select between 12-hour or 24-hour display format.

Sync Source: Allows the DVR to synchronize to a time synchronization service, either GPS (Global Positioning System), or NTP (Network Time Server), or None. When Time Sync Source is selected except 'None,' press the Sync Now button to synchronize the time immediately, or the DVR will synchronize time automatically at midnight.

Time Zone: Used with the GPS and Sync Time, as GPS satellite time comes in as GMT and needs to be offset for your time zone for proper automatic time synchronization.

REI DST: When set to On-Auto, will make the system clock change automatically with Daylight Saving Time. In regions where Daylight Saving Time is not observed, setting this item to OFF disables the Daylight-Saving Time function.

Engineering Rewrite: DST Start/DST End: The Day Light Saving Time Mode can be set to 'On-Auto', 'OFF, or to 'On-Manual'. When the DST Mode is set to 'On-Auto', the Daylight-Saving Time triggers will conform to the existing US 2005 rules. When the DST Mode is set to 'On-Manual', the Daylight-Saving Time triggers can be changed to any of the first, second, third, fourth, or last week of any month, not overlapping.

---

## HD5 Series Mobile DVR

---

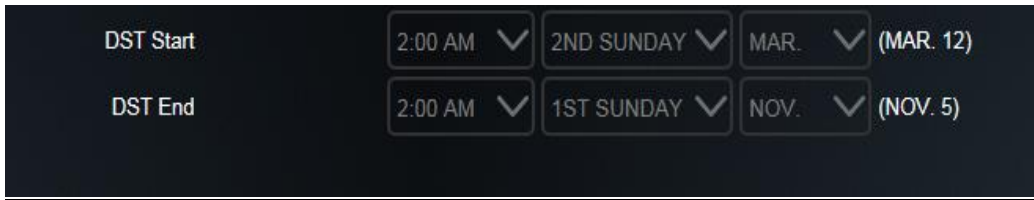

DST Start	2:00 AM	2ND SUNDAY	MAR.	(MAR. 12)
DST End	2:00 AM	1ST SUNDAY	NOV.	(NOV. 5)

Figure 25: Custom DST Triggers

### Start Up Menu

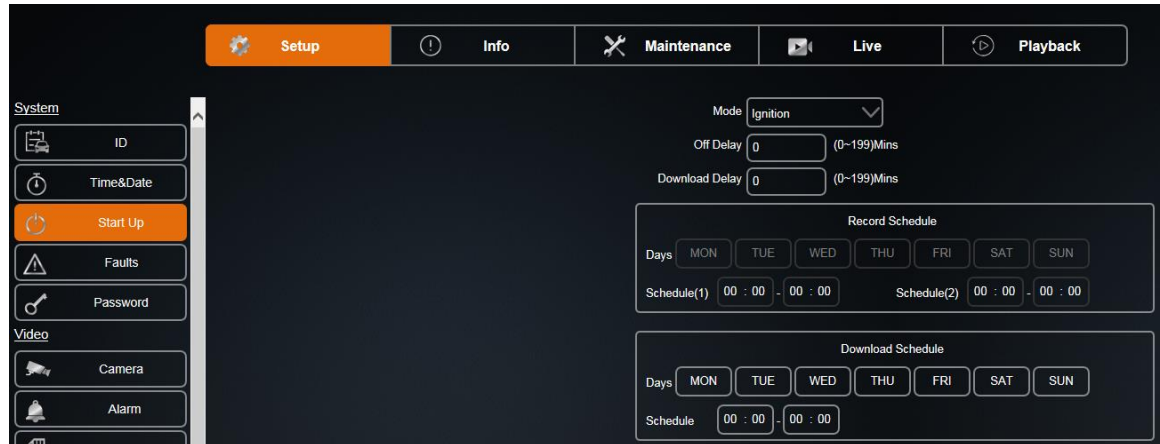

The screenshot shows the 'Start Up' menu in Ignition Mode. The 'Start Up' option is highlighted in the left sidebar. The main area displays the following settings:

- Mode: Ignition
- Off Delay: 0 (0-199)Mins
- Download Delay: 0 (0-199)Mins
- Record Schedule: Days (MON, TUE, WED, THU, FRI, SAT, SUN), Schedule(1) 00:00 - 00:00, Schedule(2) 00:00 - 00:00
- Download Schedule: Days (MON, TUE, WED, THU, FRI, SAT, SUN), Schedule 00:00 - 00:00

Figure 26: Start Up Menu in Ignition Mode

The Start Up Menu allows the user to determine when the DVR starts/stops recording video and how long the DVR stays on after shutting off the ignition.

Mode: Select from the following three Mode settings; Ignition, Schedule, Either Ignition or Schedule.

Ignition: DVR starts recording as long as ignition signal stays on.

Schedule: DVR starts recording only by schedule regardless of ignition signal.

Either Ignition or Schedule: DVR starts recording by schedule or when ignition is on at the same time.

Off Delay: The number of minutes the DVR records after the ignition is turned off. Ranges between 0-199 minutes.

Download Delay: The number of minutes the DVR stays on and not recording after the ignition is off and off delay has expired.

Record Schedule: The days and times the DVR will turn on and record automatically in any schedule mode.

Download Schedule: The days and times the DVR will turn on and not record to allow further downloading of video.

---

## HD5 Series Mobile DVR

---

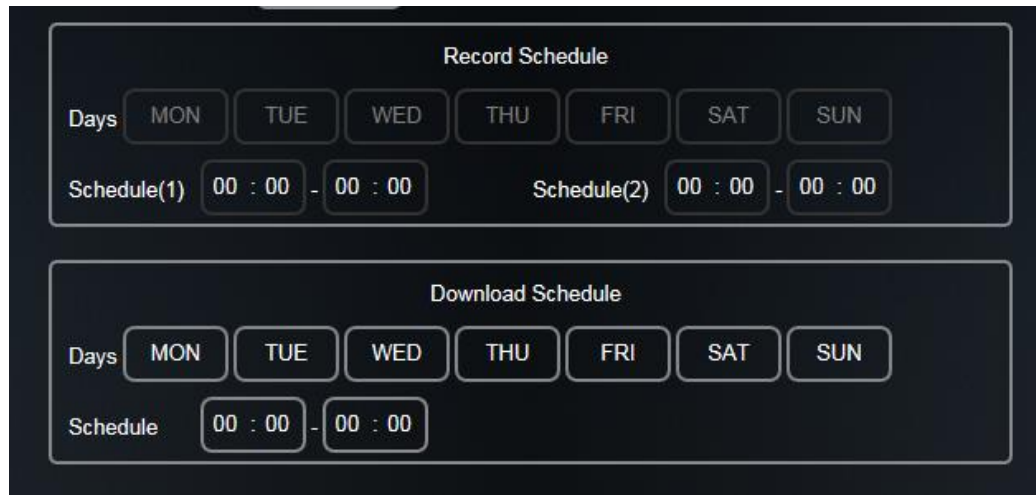

Figure 27: Record Schedule Menu

### Faults Menu

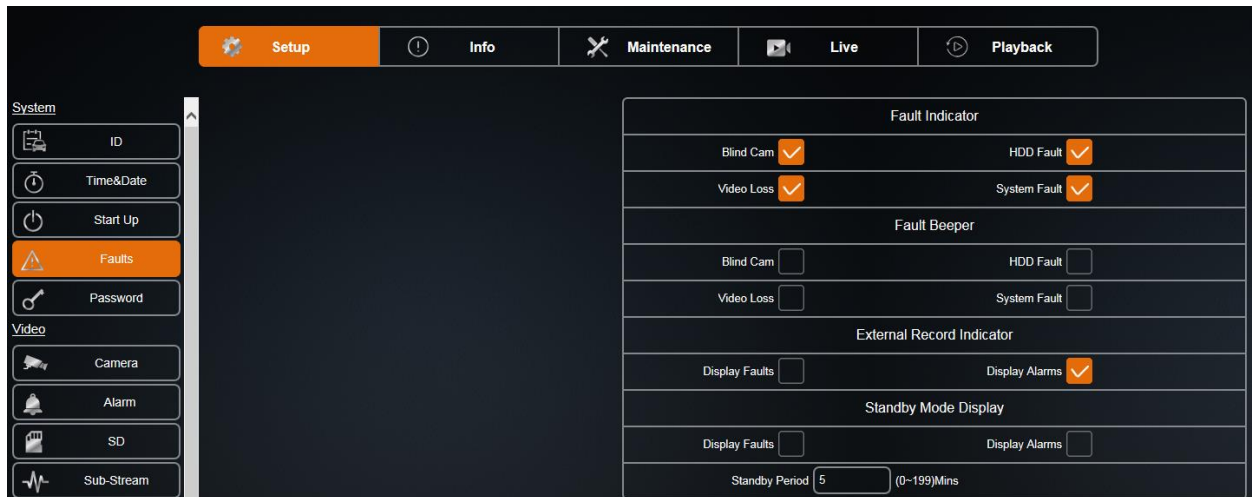

Figure 28: Faults

The Audio/Visual Setup menu enables the DVR to display an Audio/Visual alert if the DVR is experiencing an alert condition.

**Fault Indicator:** The types of alerts/faults that will be displayed on Fault Indicator.

**Blind Camera:** Camera blocked by objects.

**Video Loss:** DVR not receiving camera video.

**HDD Fault:** DVR not able to record video onto HDD.

**System Fault:** DVR experiencing problems such as voltage too high or too low.

**Fault Beeper:** The types of alerts/faults that will cause the fault beeper to activate.

**Blind Camera:** Camera blocked by objects.

---

## HD5 Series Mobile DVR

---

Video Loss: DVR not receiving camera video.

HDD Fault: DVR not able to record video onto HDD.

System Fault: DVR experiencing problems such as voltage too high or too low.

External Record Indicator: Display alarms or faults on the External Record Indicator.

Display Faults: Allows DVR to display faults.

Display Alarms: Allows DVR to display alarms.

Standby Mode Display: Display alarms or faults when the DVR is in standby mode.

Display Faults: Allows DVR to display faults in standby mode.

Display Alarms: Allows DVR to display alarms in standby mode.

Standby Period: Number of minutes to display alarms or faults in standby mode.

### Password Menu

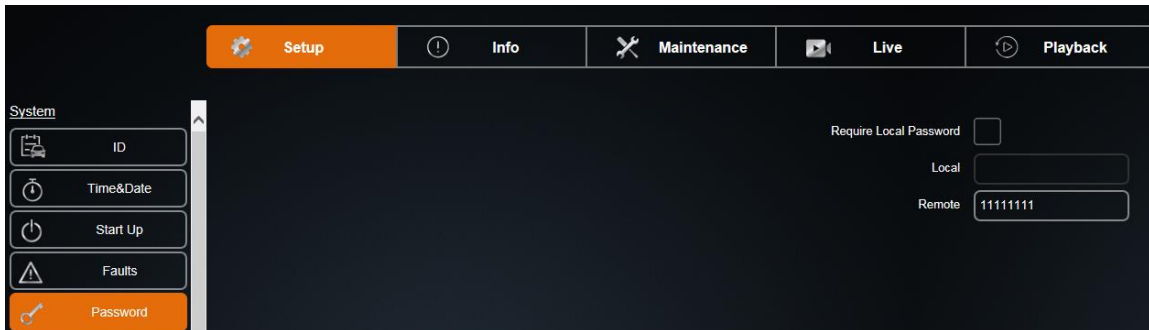

Figure 29: Password

Use the Password Menu to secure the DVR with a password.

Require Local Password: When set to 'On,' a password is required when entering the setup menu using a monitor and mouse.

Local: Password required when Require Local Password is set to 'On.'

Remote: Password required for access to the DVR-hosted configuration menu webpages.

---

# HD5 Series Mobile DVR

---

## Video Setup

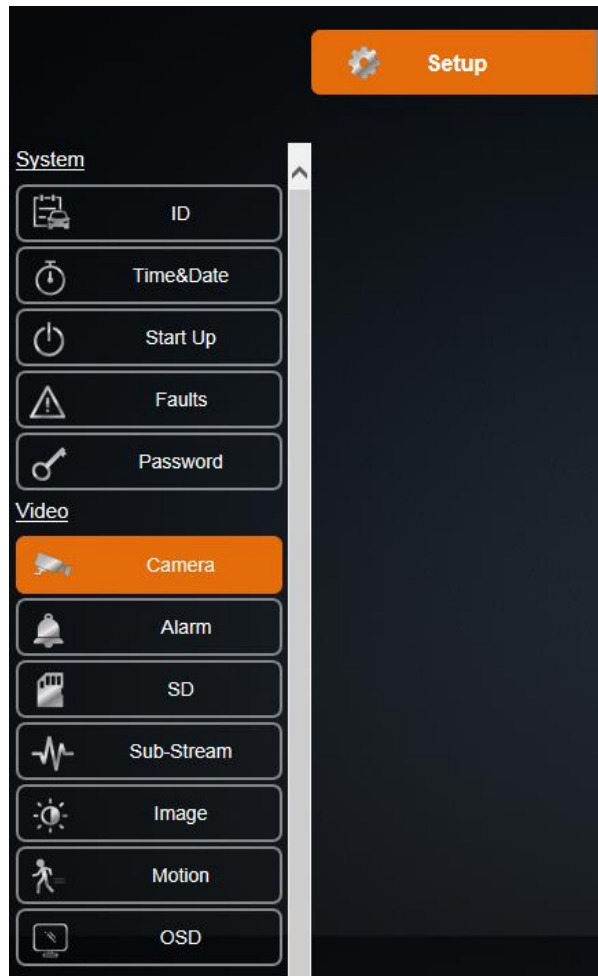

Figure 30: Video Setup

Video: The Video setup section of the menu is subdivided into seven main categories, Camera, Alarm, SD, Sub-Stream, Image, Motion and OSD.

Under Video, the channels can be enabled or disabled and the camera configuration can be set up. It is possible to setup the amount of time to record before and after alarms. Users can configure the system to record to SD card for alarms, configure the sub-stream settings, and change the settings for the image. Users can also setup motion detect and motion alarms and configure the OSD.

---

# HD5 Series Mobile DVR

---

## Camera Menu

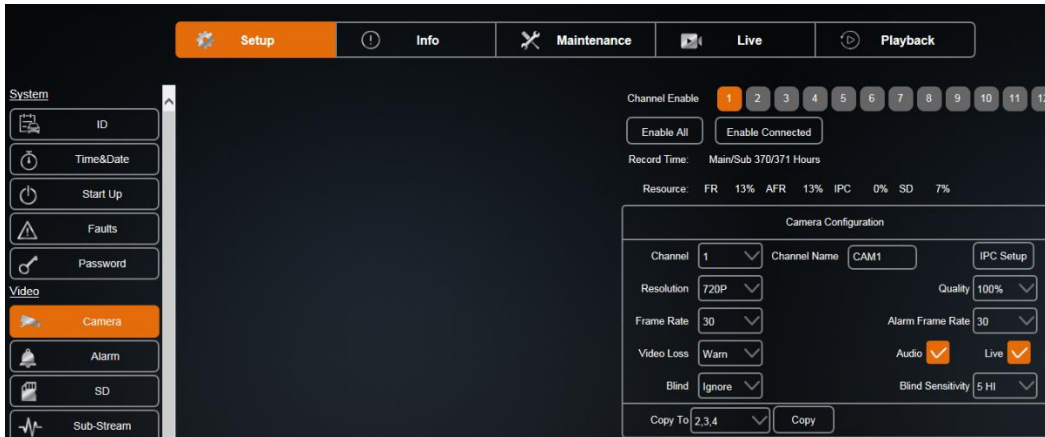

Figure 31: Camera – Camera Setup

The Camera Setup subsection of the Video Setup section allows the user to change all the related camera record settings, such as number of cameras, resolution, frame rate, etc.

Channel Enable: Custom camera record setting for each camera.

Enable All: Enable all channels.

Enable Connected: Enable channels with currently connected cameras.

Record Time: The amount of time the HDD can record under the current camera setup. Main Stream/Total Record Time.

Resource FR/AFR/IPC/SD: Non-alarm and Alarm Frame rate percentage at current camera setup.



Figure 32: Custom Record Settings

---

## HD5 Series Mobile DVR

---

The Camera Configuration setting allows a customized record setting to each individual camera.

- Channel:** Enables channel to display on screen in the Channel Name cell when selected. Note: When Live is selected, but Rec is not selected the DVR only displays that camera video but does not record it.
- Resolution:** Record video resolution. (Camera dependent, up to 1080p)
- Frame Rate:** Video frame rate during non-alarm recording. Any number between 1 and 30 can be selected.
- Video Loss:** User can select one of three options: Ignore, Warn and Alarm.
- Blind:** User can choose between three options: Ignore, Warn, and Alarm.
- IPC Setup:** Click to open an IP setup menu to select IP camera types.
- Quality:** Video quality. The scale ranges from 100% being highest taking up more HDD space; to 10% being lowest taking up less HDD space.
- Alarm Frame Rate:** Video frame rate during alarm recording: can select any number between 1 and 30.
- Audio:** Record camera audio if selected.
- Live:** Displays live video.
- Blind Sensitivity:** User can choose between 1 – LO and up to 5 – HI.
- Copy To:** Select the cameras to copy the settings to and click Copy.

### IP and Port Setup Menu

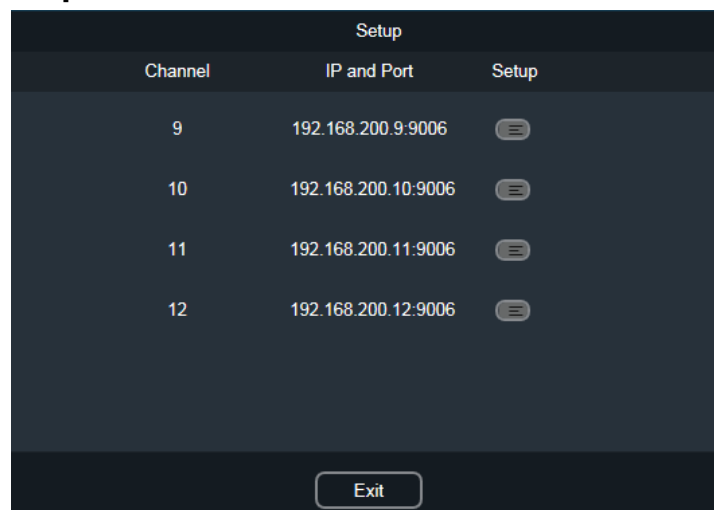

Figure 33: IPC Setup Pop-up Window



---

# HD5 Series Mobile DVR

---

## Network Setup Menu

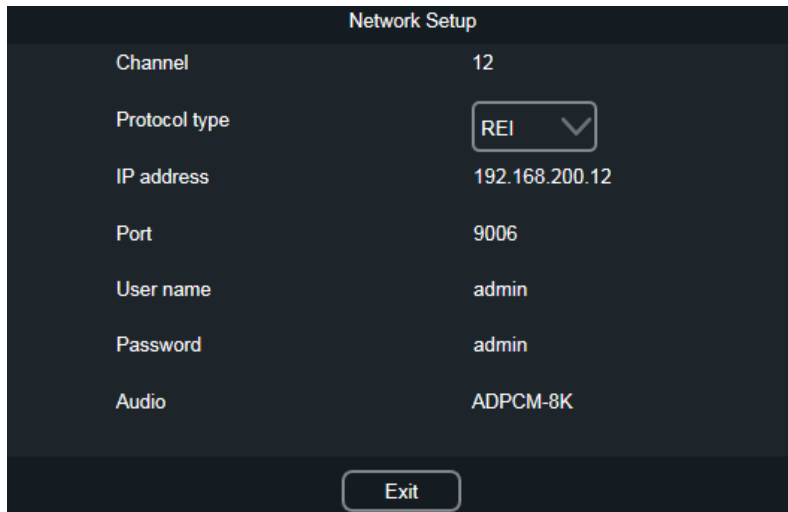

Figure 34: Individual Channel Network Setup

Channel: The number of the channel being setup

Protocol Type: REI or ONVIF

IP address: Internet protocol address of the channel being setup

Port: Port identification for the channel

User name: Used to enter camera configuration menu

Password: Used to enter camera configuration menu

Audio: Audio codec currently being used

Click Exit after setup is complete.

For additional information about IP camera configuration, refer to the HD5 Series Models section of the REI Customer Support Site by clicking on the following link - <http://www.radioeng.info/>

## Alarm Menu

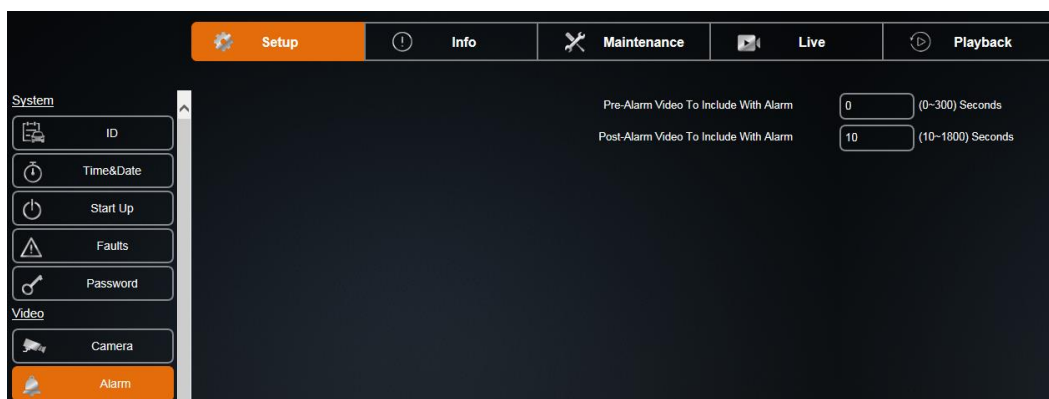

Figure 35: Alarm Setup

---

## HD5 Series Mobile DVR

---

Pre-Alarm Video to include with Alarm: Range is set between 0-300 seconds.

Post-Alarm Video to Include with Alarm: Range is set between 10-1800 seconds.

### SD Menu

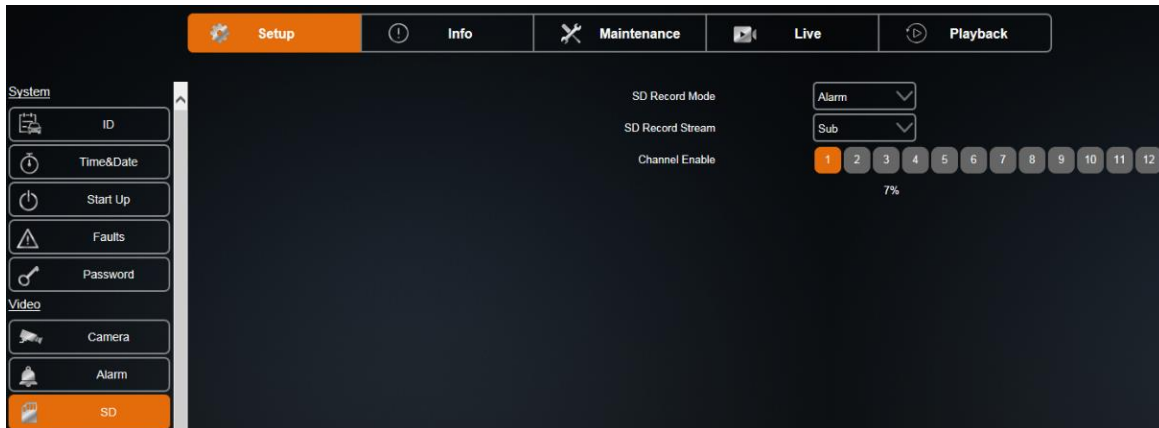

Figure 36: SD Setup

SD Record Mode: Select Alarm or Mirror

Alarm: Records only alarm video to the SD card.

Mirror: Records video to the SD card continuously.

SD Record Stream: Select Main or Sub

Main: Record high quality stream per the camera settings in Setup/Camera menu.

Sub: Record smaller stream per the settings in the Setup/Sub-Stream menu.

Channel Enable: Select the cameras to record to the SD card.

---

# HD5 Series Mobile DVR

---

## Sub-Stream Menu

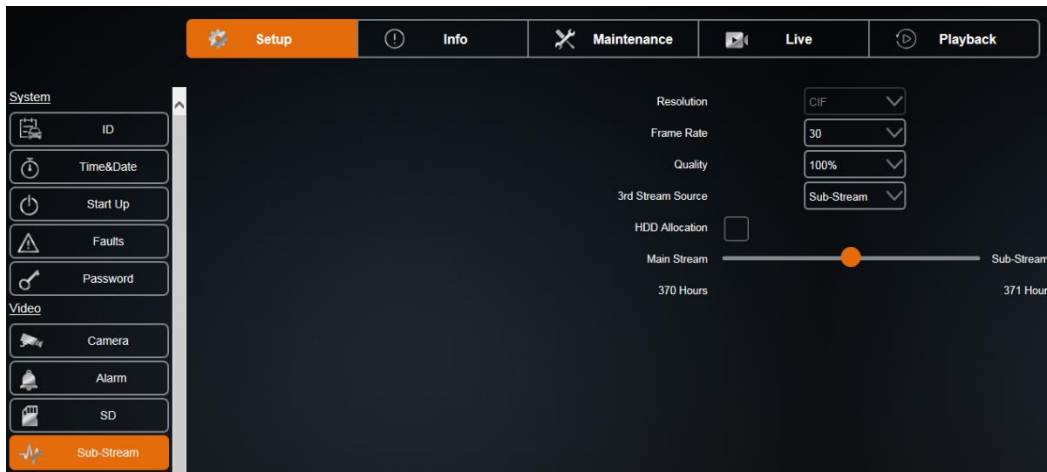

Figure 37: Sub-Stream Setup

Resolution: The resolution of the sub-stream (fixed at CIF).

Frame Rate: The frame rate of the sub-stream. Ranges between 1 and 30.

Quality: The quality (bit rate) of the sub-stream. Ranges between 10% and 100% of target bit rate.

3<sup>rd</sup> Stream Source: Stream to use as the source of the I-Frame mode in Remote Web Live View.

HDD Allocation: Check box to allow a larger duration of the sub-stream to be recorded to the HDD.

## Image Menu

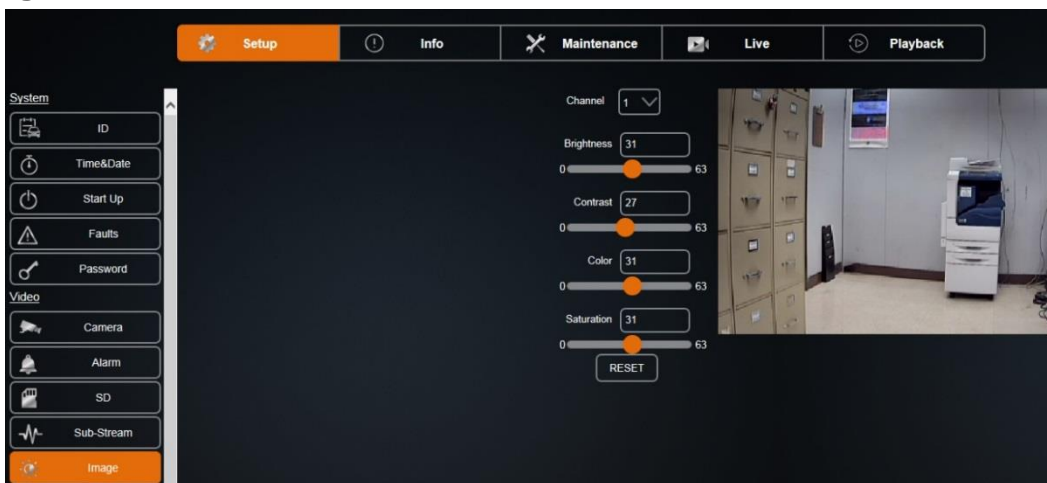

Figure 38: Image Setup

Image allows the user to adjust the camera signal to improve video quality. Each channel can be adjusted individually to suit different cameras. The result can be viewed on the right side of the screen.

---

## HD5 Series Mobile DVR

---

Channel: The channel that needs adjustment.

Brightness: Brightness adjustment for the video from 0-63.

Contrast: Contrast adjustment for the video from 0-63.

Color: Color adjustment for the video from 0-63.

Saturation: Saturation adjustment for the video from 0-63.

The settings for each channel can be customized individually. The available options are Brightness, Contrast, Color, and Saturation. The settings range from 0 to 63.

### Motion Menu

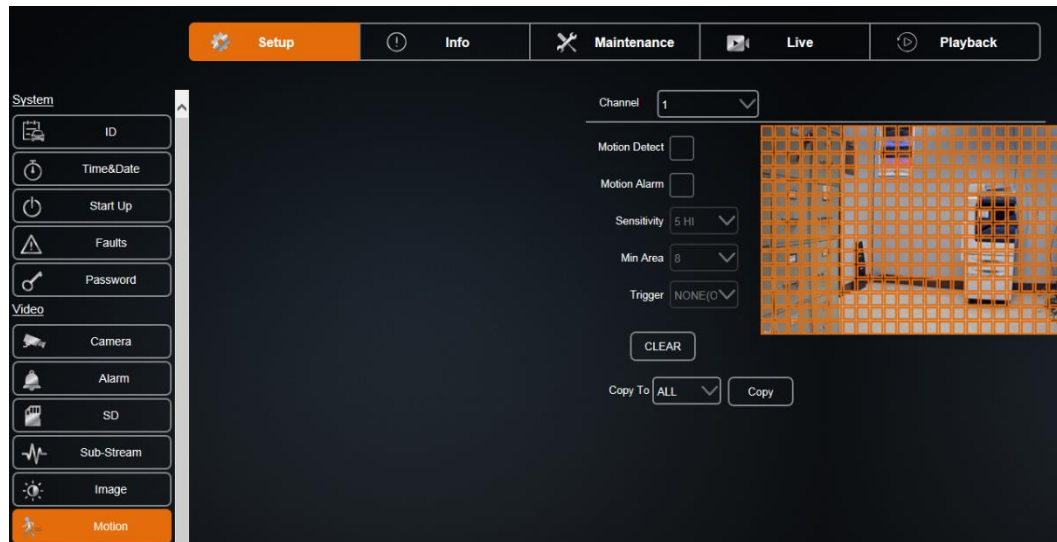

Figure 39: Motion Setup

Motion Setup menu controls the video motion detection system of the DVR. The user can enable camera motion detection individually. The system can be set to trigger an alarm when motion is detected. Sensitivity and area can also be adjusted for each camera.

Five options to customize each channel separately are available. The options are Motion Detect, Motion Alarm, Sensitivity, Min Area, and Trigger. Click Clear to start over.

Motion Detect: Enable motion detection for the selected channel.

Motion Alarm: Trigger alarm upon motion detection for the selected channel.

Sensitivity: Motion detection sensitivity within each square. Ranges between 1-LO and 5-HI.

Min Area: Minimum number of squares with motion required to trigger motion detection. Select 1, 2, 4, 8, 16, 32, or 64.

Trigger: Input that must be active to enable motion detection (INPUT 1-8, NONE equals always enabled).

Clear: Click to clear detection area.

---

## HD5 Series Mobile DVR

---

Copy To: Copy the current settings to other cameras. The ranges are individual cameras 1 through 12, All, 1-8, or 9-12.

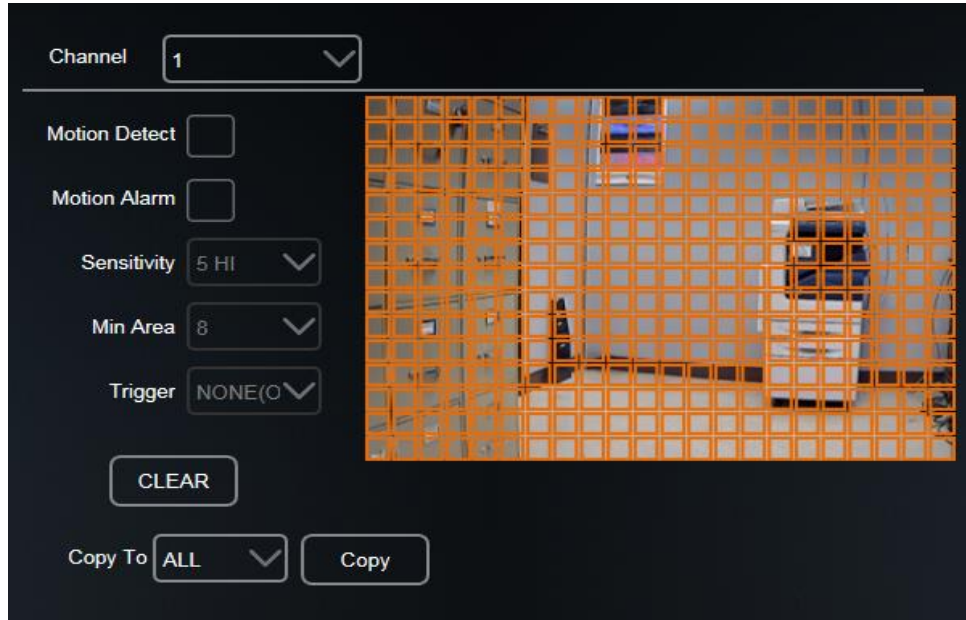

Figure 40: Motion Setup - Set Grid

Click and drag on the Set Grid screen to select the squares within the detection area.

### OSD Menu

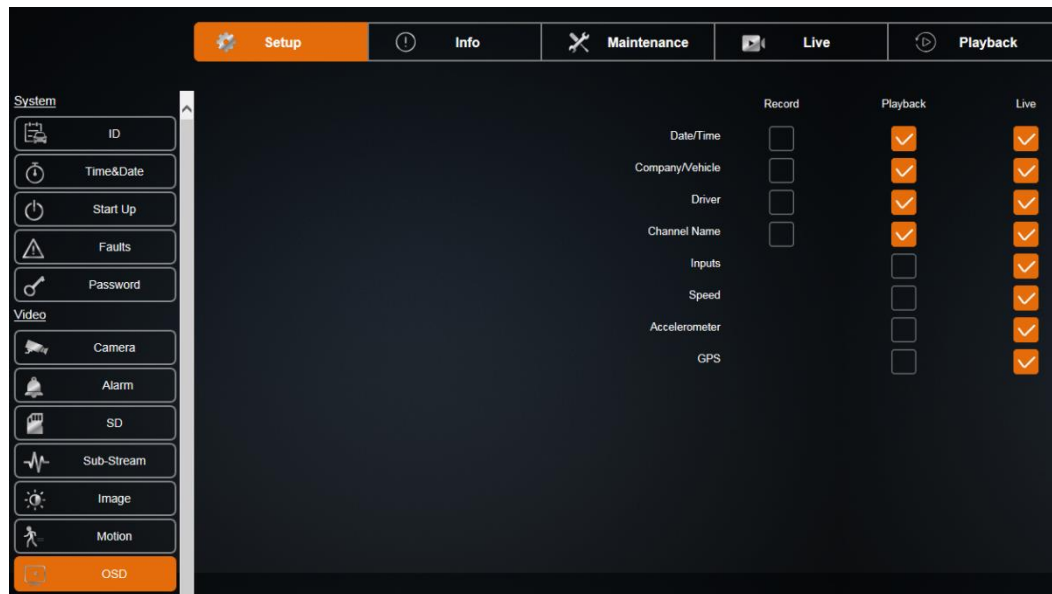

Figure 41: OSD Setup

OSD (On Screen Display): Divided into three subcategories Record, Playback, and Live.

Record: Selected data types will be recorded permanently over video.

---

# HD5 Series Mobile DVR

---

Playback: Selected data types will be displayed during playback via monitor/mouse.

Live: Selected data types will be displayed during live viewing via monitor.

## Input Setup



Figure 42: Input Setup

Input Setup: Contains all the settings to configure inputs from the DVR including: Speed, Input, Accelerometer, and GPS Port Setup.

## Speed Menu

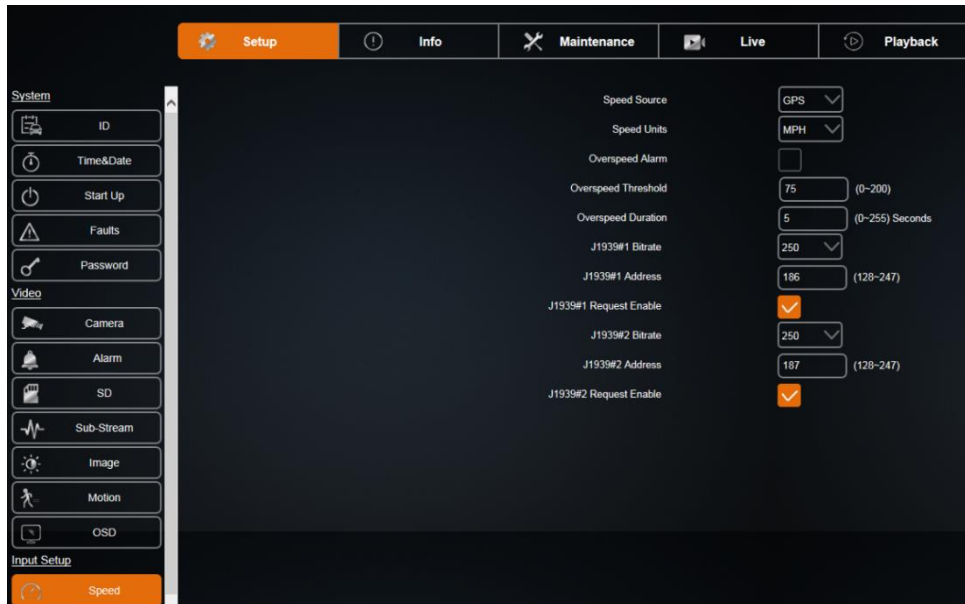

Figure 43: Speed Setup

Speed Setup Menu contains settings to change the speedometer source, speed unit, speedometer calibration, and high-speed alarm.

Speed Source: The DVR speed source; GPS, J1939#1, and J1939#2.

---

# HD5 Series Mobile DVR

---

Speed Units: MPH and KMH speed units.

Overspeed Alarm: Triggers an alarm if the speed exceeds the Overspeed Threshold for the Overspeed Duration.

Overspeed Threshold: Minimum speed that triggers an alarm. 0-200.

Overspeed Duration: Time that speed must be over the threshold to trigger an alarm. 0-255 seconds.

J1939#1 & J1939#2: Contact REI support personnel for information about configuring these parameters (if necessary). Do not alter the initial settings unless instructed.

## Inputs Menu

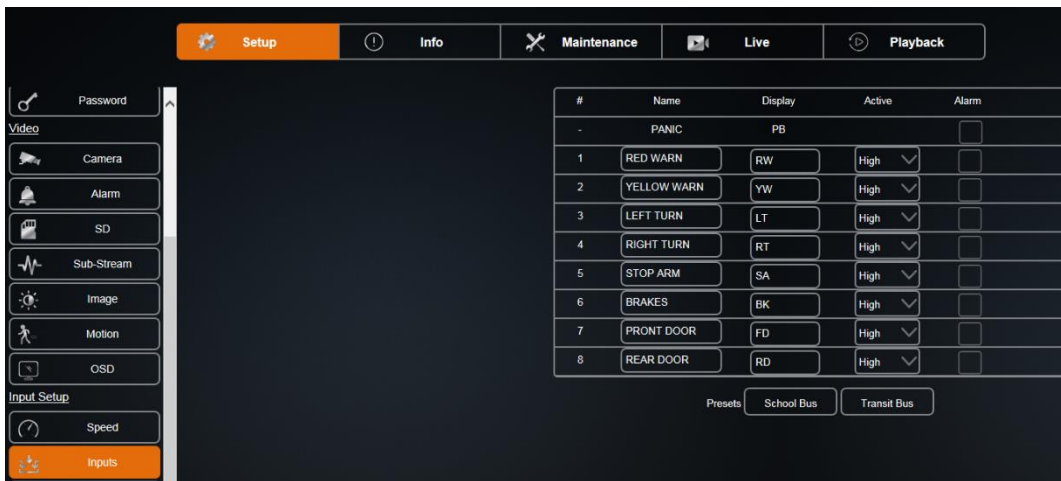

Figure 44: Inputs Setup

The Inputs Setup shows all the available inputs on the DVR. Each signal can be renamed, adjusted to active high/low, and set to trigger alarms when activated. There are two preset vehicle types to choose from: School Bus and Transit. When set to custom, each channel can have its own name and OSD abbreviation.

---

## HD5 Series Mobile DVR

---

#	Name	Display	Active	Alarm
-	PANIC	PB		<input type="checkbox"/>
1	RED WARN	RW	High <input type="button" value="v"/>	<input type="checkbox"/>
2	YELLOW WARN	YW	High <input type="button" value="v"/>	<input type="checkbox"/>
3	LEFT TURN	LT	High <input type="button" value="v"/>	<input type="checkbox"/>
4	RIGHT TURN	RT	High <input type="button" value="v"/>	<input type="checkbox"/>
5	STOP ARM	SA	High <input type="button" value="v"/>	<input type="checkbox"/>
6	BRAKES	BK	High <input type="button" value="v"/>	<input type="checkbox"/>
7	FRONT DOOR	FD	High <input type="button" value="v"/>	<input type="checkbox"/>
8	REAR DOOR	RD	High <input type="button" value="v"/>	<input type="checkbox"/>

Presets

Figure 45: Input Setup - Custom

Input #: The input numbers that correspond to the input numbers on the DVR wiring harness.

Name: Name of the Input (16 characters or less).

Display: Abbreviation shown on OSD etc. (two characters).

Active: State which is considered active (low/ground or high/+ volt).

Alarm: Triggers alarm when the input is in the active state.

Presets: Preload input names and abbreviations for School Bus and Transit Bus.



---

# HD5 Series Mobile DVR

---

## Accel Menu

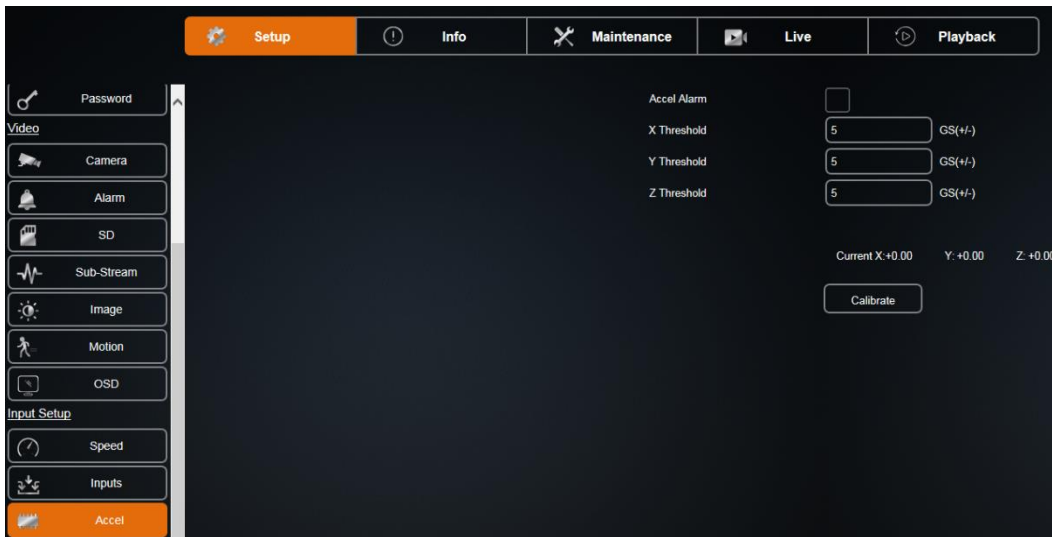

Figure 46: Accelerometer Setup

The Accel Menu gives user options to configure the accelerometer.

Calibrate Accelerometer: Accelerometer must be calibrated after installation.

Click the Calibrate button to calibrate the accelerometer.

Current Values: Current acceleration readings from the accelerometer.

Accel Alarm: Trigger an alarm when either the X/Y/Z Threshold is exceeded.

X Threshold: Forward and backward acceleration/de-acceleration that triggers an alarm.

Y Threshold: Left or right acceleration/de-acceleration that triggers an alarm.

Z Threshold: Up and down acceleration/de-acceleration that triggers an alarm.

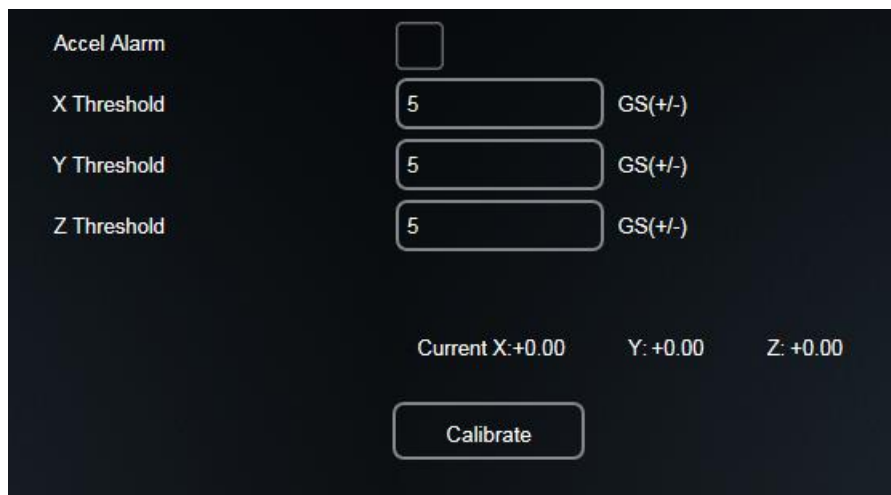

Figure 47: Accel Alarm

---

# HD5 Series Mobile DVR

---

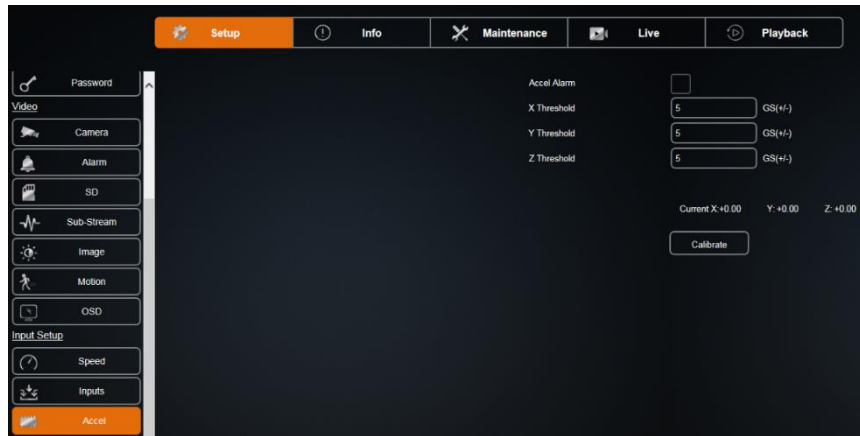

Figure 48: Accelerometer Threshold

## GPS Port Menu

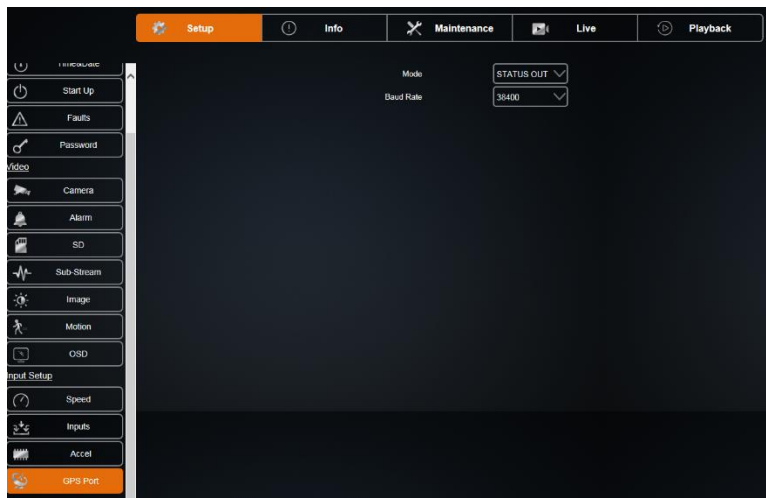

Figure 49: GPS Port

Mode: Set the mode of the GPS port Status Out or External GPS (input).

Baud Rate: Baud Rate of the GPS Port (4800 – 115200). The default setting for the REI GPS Module is 38400.

---

# HD5 Series Mobile DVR

---

## Network Setup



Figure 50: Network Setup

Network: The user can configure the DVR to connect to the network. It has inputs for WAN/LAN settings, server, WIFI, Cellular connections and Routes.

## WAN/LAN Setup

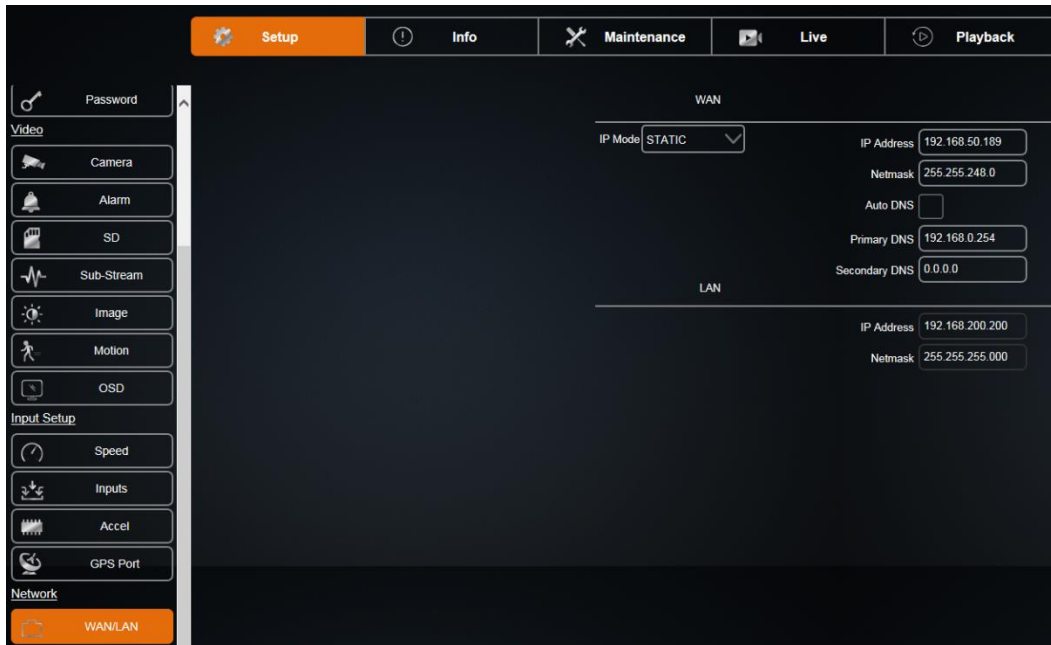

Figure 51: General Network Setup

WAN/LAN setup is where the user sets up the network configuration if using the Ethernet port located on the front and back of the DVR.

### WAN

IP Mode: Static or Dynamic (DHCP) IP address.

---

## HD5 Series Mobile DVR

---

IP Address: WAN IP Address.

Netmask: WAN Netmask.

Auto DNS: Use DHCP-provided IP address for DNS if checked.

Primary DNS: Primary DNS Server IP address for WAN

Secondary DNS: Secondary DNS Server IP address for WAN

Contact your IT specialists for assistance configuring this page.

### Server

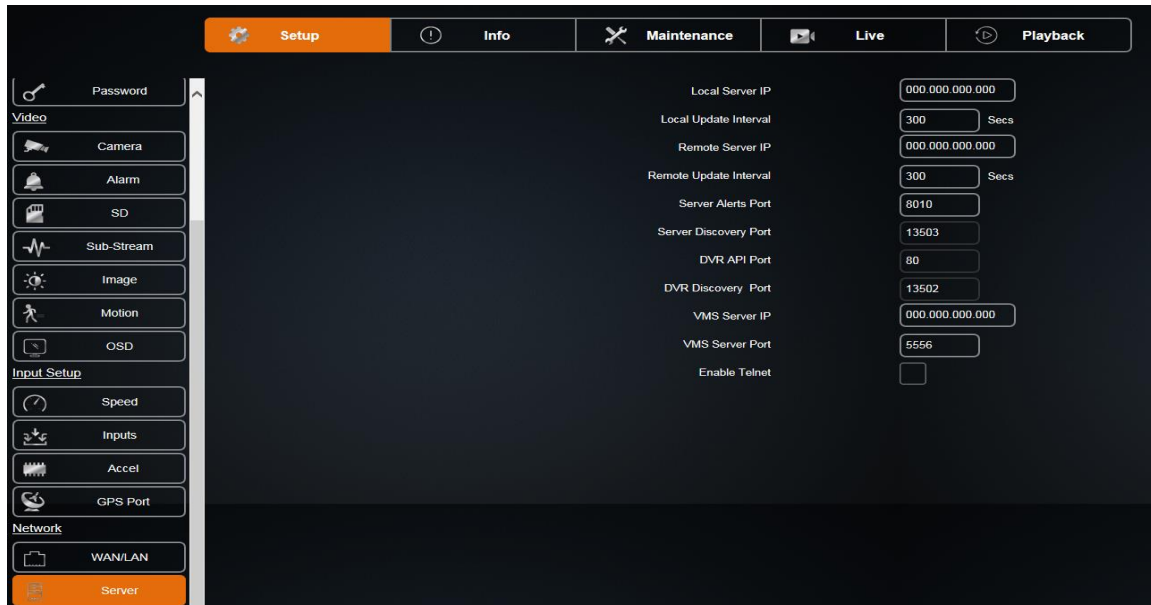

Figure 52: Server

Local Server IP: IP address of the ARMOR server on local network (WIFI network).

Local Update Interval: Frequency that DVR reports to local ARMOR server.

Remote Server IP: IP address of the ARMOR server on the WAN network (Cellular network).

Remote Update Interval: Frequency that DVR reports to the WAN network ARMOR server.

Server Alerts Port: ARMOR server alert port number.

Server Discovery Port: ARMOR server discovery port number.

DVR API Port: DVR port used by ARMOR for access.

DVR Discovery Port: DVR port used by ARMOR for discovery.

VMS Server IP: VMS server IP address.

VMS Server Port: VMS server port.

---

## HD5 Series Mobile DVR

---

Enable Telnet: Enable Telnet access on DVR for remote administration. Note: Setting not saved. Clears on reboot.

### WIFI Menu

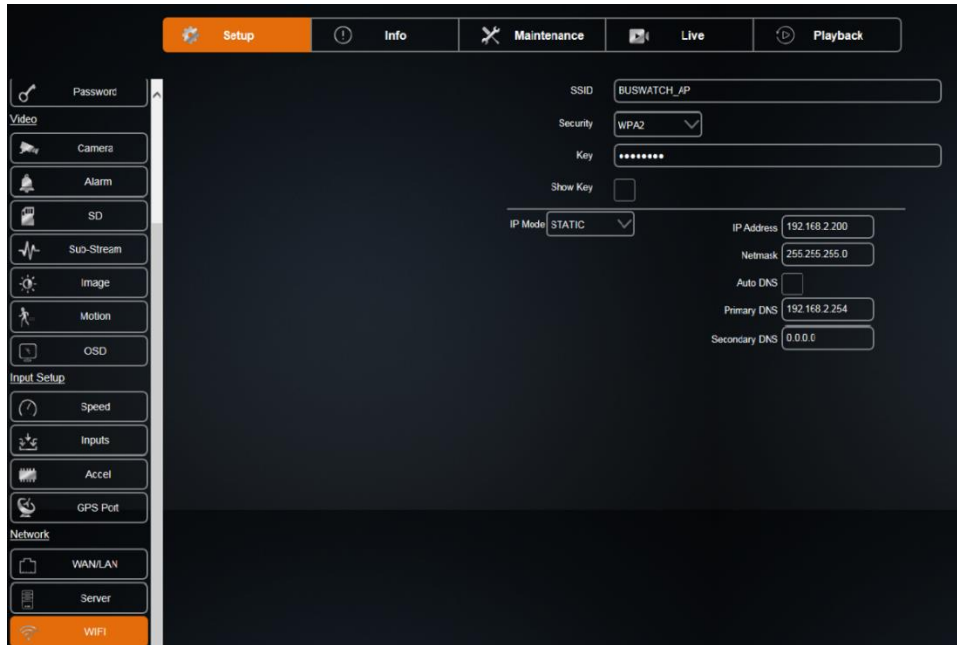

Figure 53: WIFI Setup

The Wireless Network settings allow the DVR to be connected wirelessly. It also supports Auto IP detection for easy set up.

SSID: SSID of the access point of the WIFI network.

IP Mode: Static or Dynamic (DHCP) IP address.

IP Address: WIFI IP Address.

Netmask: WIFI Netmask.

Security: Security type used by WIFI network. It must match access point setting.

Key: Security key used by WIFI network. It must match access point setting.

Auto DNS: Use DHCP-provided IP address for DNS if checked.

Primary DNS: Primary DNS Server IP address for WIFI network

Secondary DNS: Secondary DNS Server IP address for WIFI network

Contact your IT specialists for assistance configuring this page.

---

# HD5 Series Mobile DVR

---

## Cellular Network

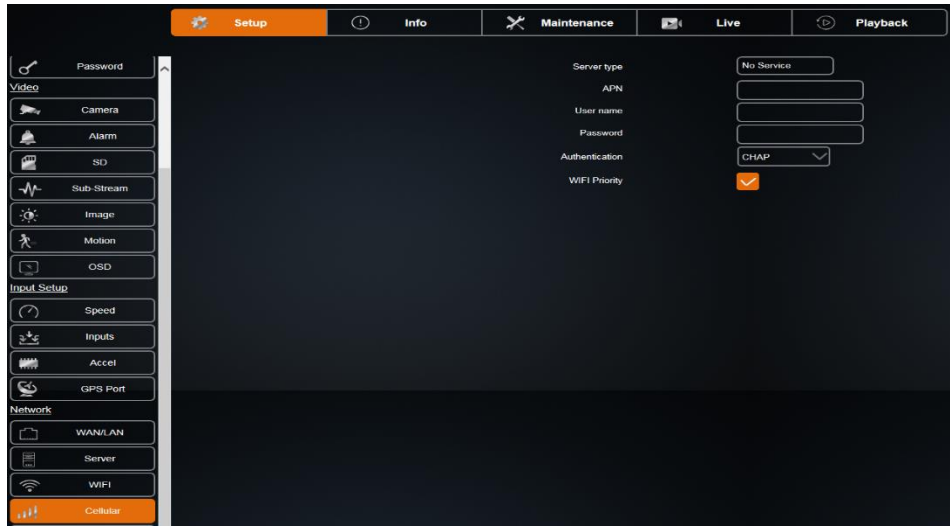

Figure 54: Cellular Setup

Configuration for internal cellular card. Applicable to cellular models only. Contact your IT specialists for assistance configuring this page.

## Route

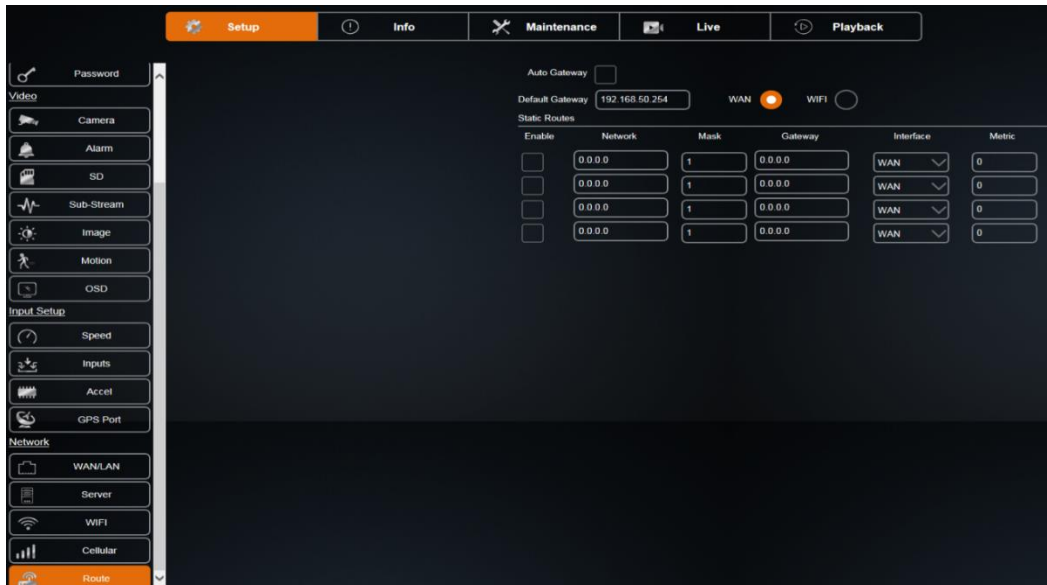

Figure 55: Route Setup

Configuration of default gateway and static routing. Contact your IT specialists for assistance configuring this page.

---

# HD5 Series Mobile DVR

---

## Info

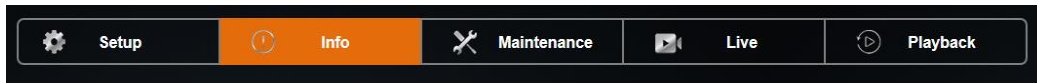

Figure 56: Info Menu

Info: Display only tab that displays status information of channels, active alarms, system information, WAN/Cell and WIFI connections, the system firmware versions, and logs.

Displayed data is spread across eight subsections: Camera, Inputs, Alarms, System, WAN/Cell, WIFI, Versions, and Logs.

## Camera

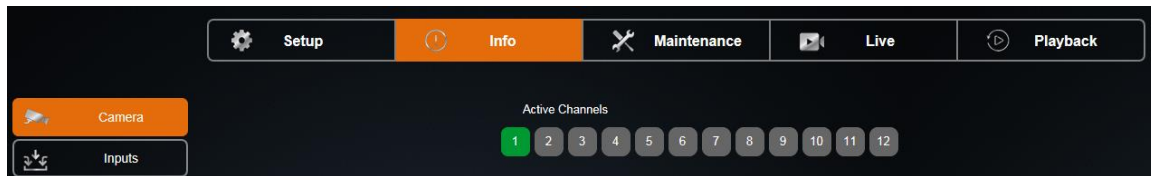

Figure 57: Camera Tab

Active Channels: Channels which have cameras currently connected and are enabled for recording.

## Inputs



Figure 58: Inputs Tab

Ignition: Current state of vehicle ignition.

Speed: Current vehicle speed.

Accelerometer: Accelerometer is connected.

Data X: Y: Z: Current Accelerometer data values.

GPS: Current GPS coordinates.

J1939: Current status of J1939 interface.

---

# HD5 Series Mobile DVR

---

## Alarms

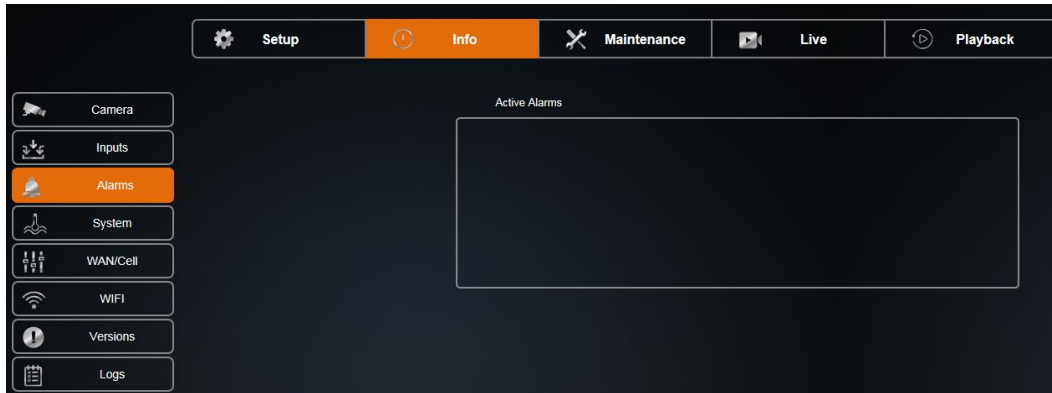

Figure 59: Alarms Tab

Active Alarms: Alarms that are currently occurring.

## System

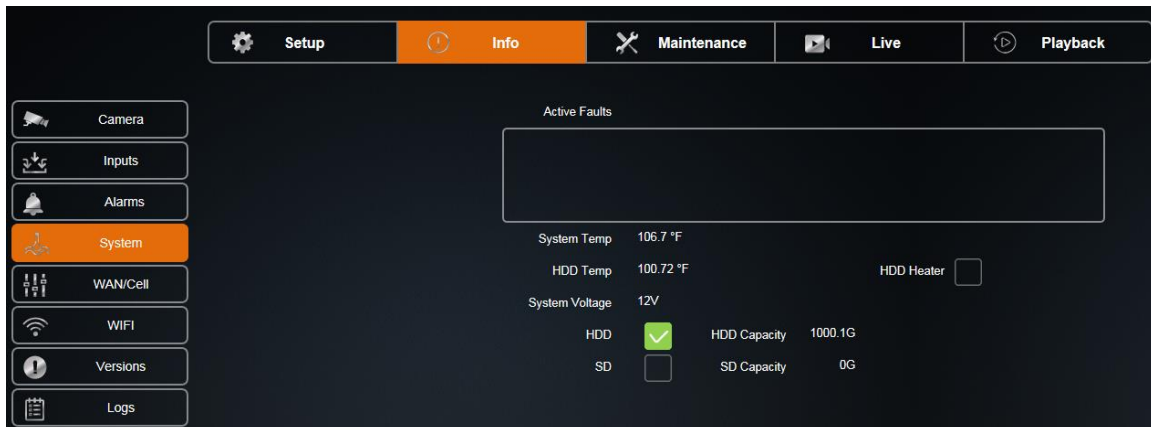

Figure 60: System Tab

Active Faults: Faults that are actively occurred.

System Temp: Current system temperature.

HDD Temp: Current hard drive temperature.

HDD Heater: HDD heater is On or Off.

System Voltage: Current system input voltage.

HDD/HDD Capacity: Size of the currently installed HDD.

SD/SD Capacity: Size of the currently installed SD card.



# HD5 Series Mobile DVR

## WAN/Cell

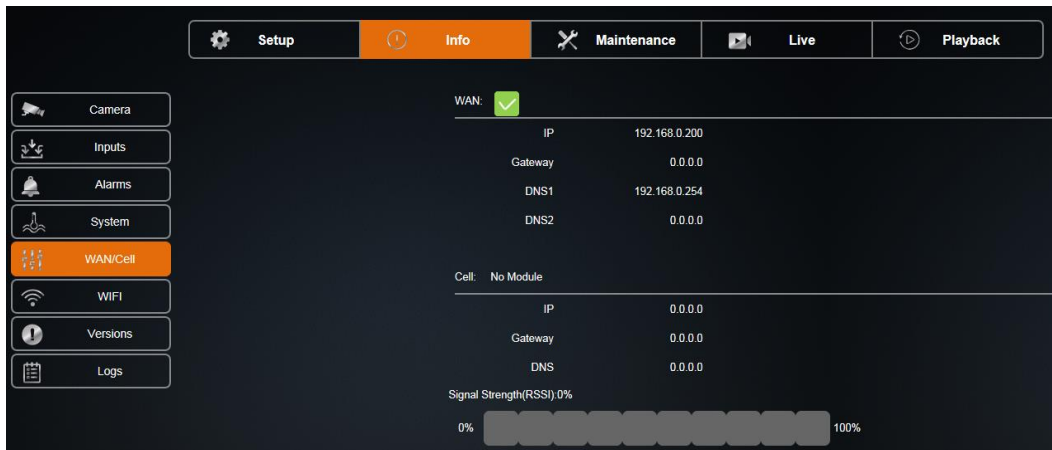

Figure 61: WAN/Cell Tab

WAN: Current IP address etc. of the WAN interface.

Cell: Current IP address etc. of the internal cellular interface.

Signal Strength (RSSI): Current signal strength of the internal cellular interface.

## WIFI

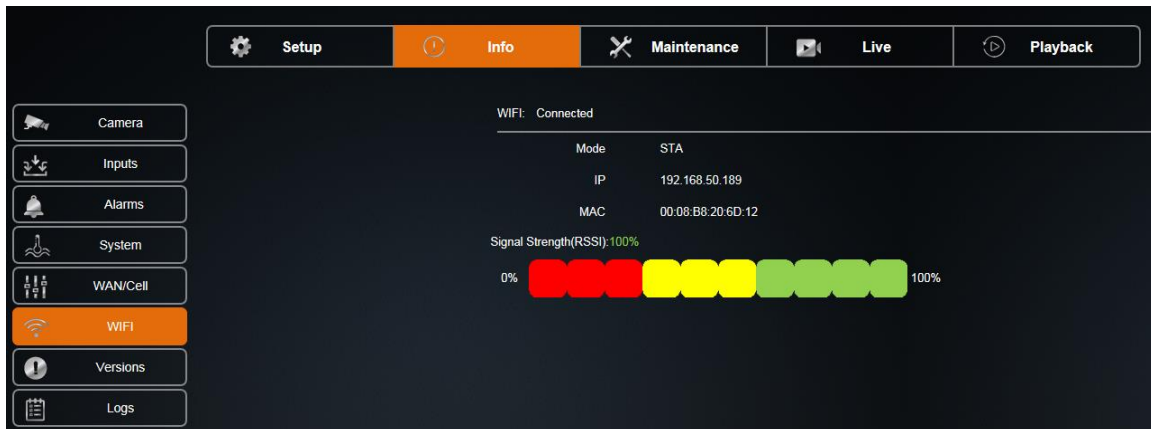

Figure 62: WIFI Tab

WIFI: Current mode and IP address of the WIFI interface.

Signal Strength (RSSI): Current signal strength of the internal WIFI interface.

---

# HD5 Series Mobile DVR

---

## Versions

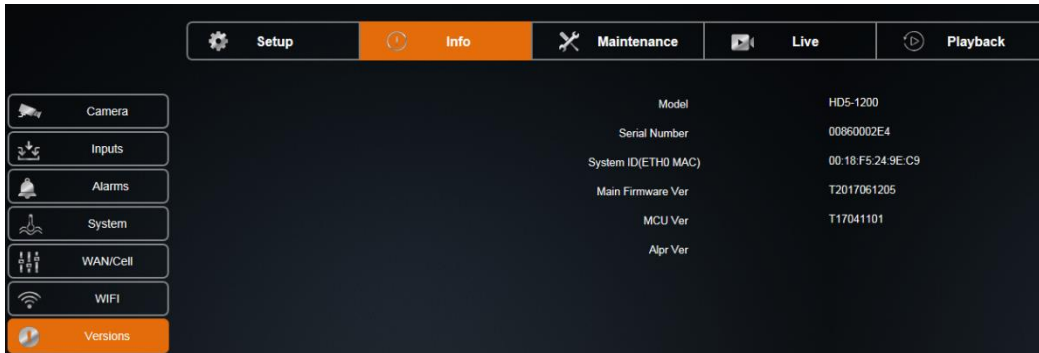

Figure 63: Versions Tab

Version of the Main/MCU Firmware, Serial Number, System ID, Model, MCU, and ALPR.

## Logs

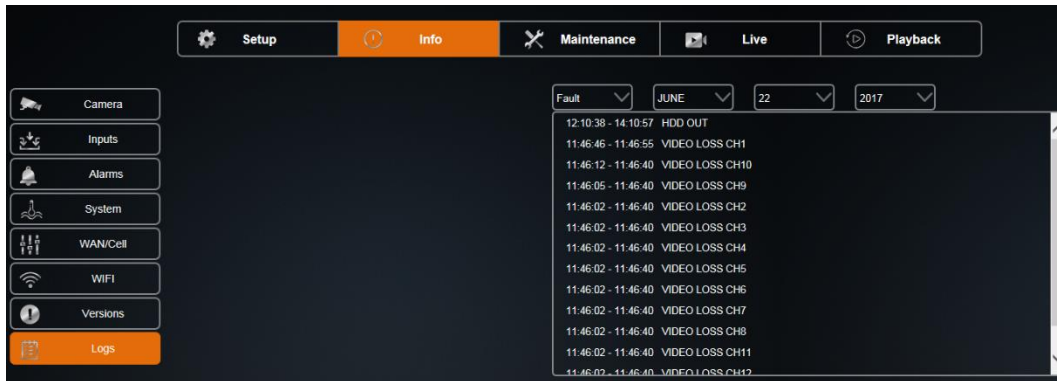

Figure 64: Logs Tab

Access to the system or fault logs by date.

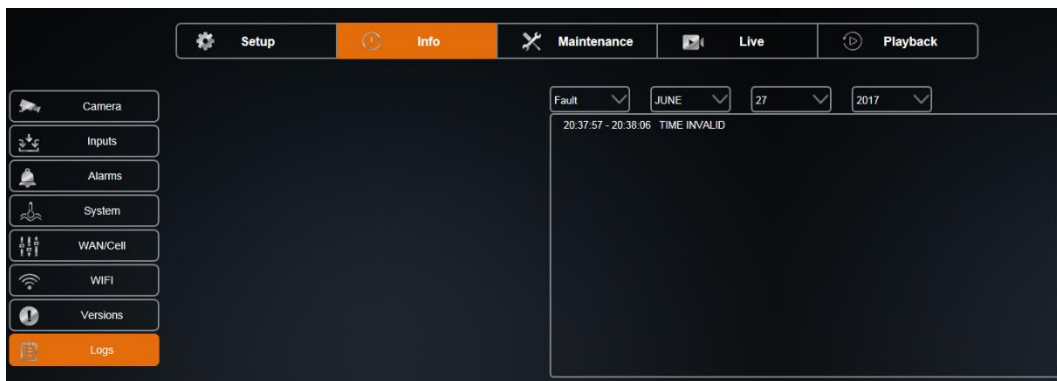

Figure 65: Logs – Search Result

---

# HD5 Series Mobile DVR

---

## Maintenance

Maintenance allows upgrades to the firmware, import or export the configuration, reset to defaults, or format the HDD, SD card, or USB media.

## Firmware



Figure 66: Upgrade Firmware

Click Browse to select the new firmware file from a location on your PC, click Upgrade to upgrade the firmware using the selected file.

## Config Menu

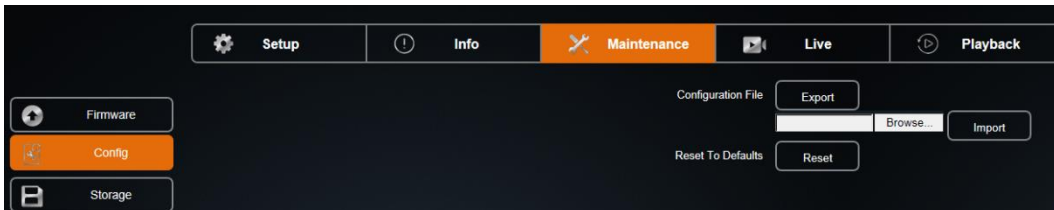

Figure 67: Export Configuration

Click Export to save the configuration to your PC.

Click Browse to select a previously saved configuration file from a location on your PC, click Import to apply the saved configuration. Note: Network settings and system ID will not be overwritten by this function.

Click Reset to reset ALL configuration settings to the factory default. Note: This will change all network settings, including WIFI back to factory defaults.

## Storage

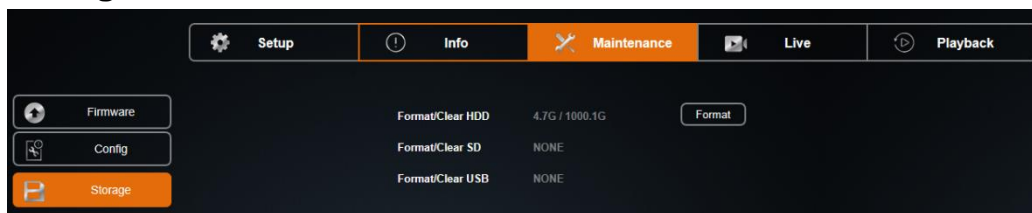

Figure 68: Storage Tab

Format/Clear HDD: Format/clear (erase) the HDD.

Format/Clear SD: Format/clear (erase) the SD.

Format/Clear USB: Format/clear (erase) the USB media.

---

# HD5 Series Mobile DVR

---

## Live



Figure 69: Live Menu

Live: Allows the user to view any or all cameras live.

Selecting Live opens a real-time view of the camera. The bar at the bottom of the screen has controls to select which channels are displayed, if info window is displayed, and to return to the Setup menu.

The following two buttons are at the left of the row of the channel buttons:



Figure 70: Channel Bar

## Info Button



Click the button to display or hide the information panel as shown below.

A screenshot of an information panel for a vehicle. The panel has a dark blue background with white text. At the top, it says '12 Chief-K145' with a close button (X) on the right. Below this, there are several rows of data: 'FW Version T2016120690', 'MCU Version T16120601', 'Company Name Chief', 'Vehicle Number K145', 'ACC -0.363,-0.129,-0.219 (g)', 'GPS LON:96 1'59.54"West LAT:41 14'55.89"North', 'Speed 9.0 MPH', 'Voltage 13.4 V', and 'Temperature 50.00 °F'. At the bottom, there is a row of colored buttons: RW (green), YW (green), LT (green), RT (green), SA (green), BK (green), FD (green), RD (green), PB (green), and IGN (red).

Figure 71: Sample Info Data Table

## Settings button

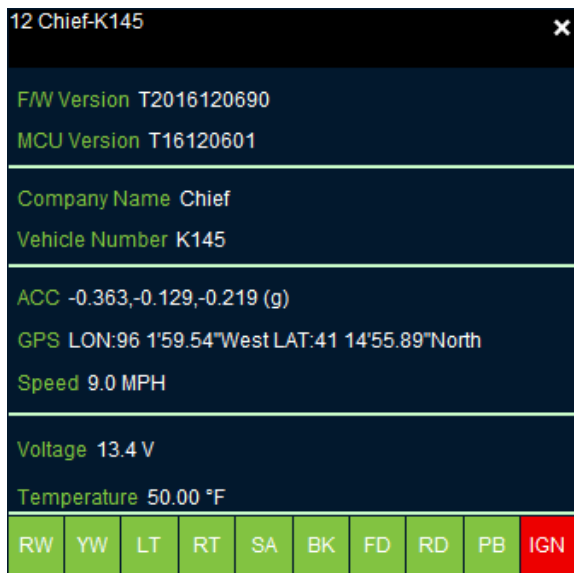

Click this button to exit Live View and return to the Setup menu.

---

# HD5 Series Mobile DVR

---

## Channel Selection

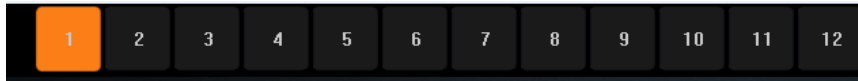

Figure 72: Channel Selection Buttons

Select individual channels for Live View.

## Play Back



Figure 73: Playback Menu

Playback: Videos recorded on the HDD can be fully accessed from the Play Back menu. The user can search videos by using the Time/Date Search function, and the Alarm Search function. Videos can also be backed up onto an external storage drive using the USB Backup function.

## Video (Time/Date Search)

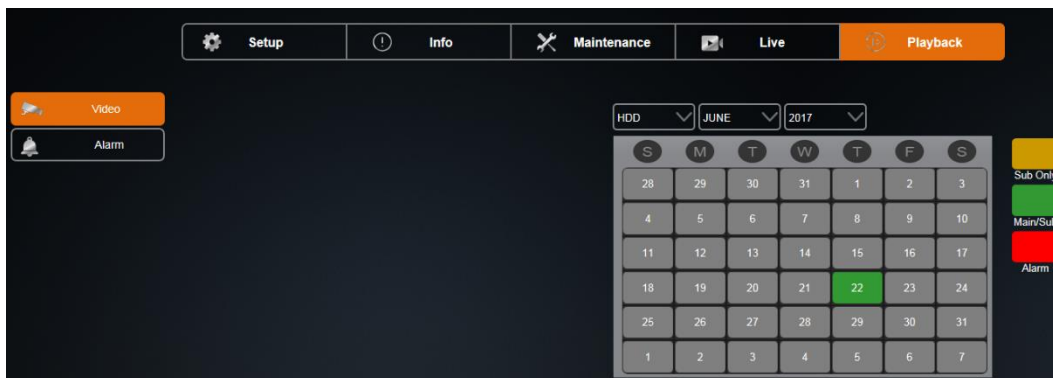

Figure 74: Video Tab - Time/Date Search for Date

The Time/Date Search function gives the user the ability to search videos by choosing the Time and Date.

The screen shows a calendar that contains videos.

Select the video storage device (HDD or SD), month, and year of the desired video.

The calendar will display all days in the selected year and month which contain video. If the day is green Main stream and Sub stream video is available for that day. If day is yellow Sub stream video only is available for that day. If the day is red, the day contains Alarm video (Main and/or Sub stream).

Click the desired day on the calendar to start playback at the time of the earliest video on that day.

---

# HD5 Series Mobile DVR

---

## Alarm

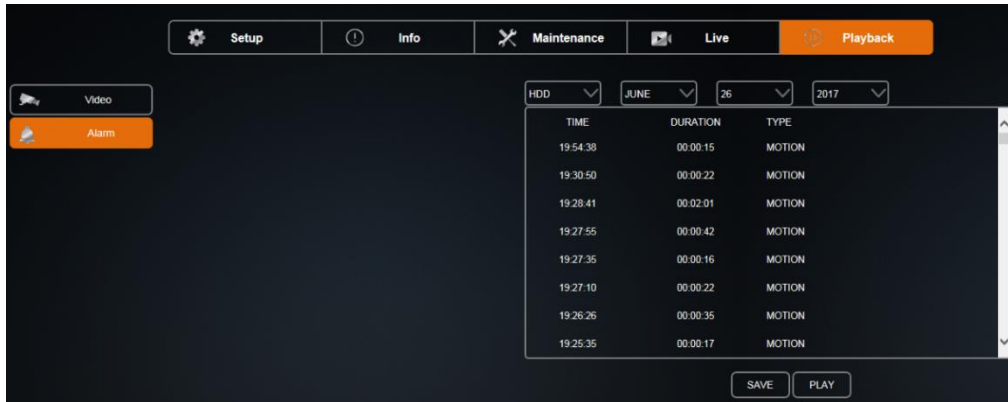

Figure 75: Alarm Tab - Alarm Search

The Alarm Search function gives the user the ability to search alarms from a list.

The screen shows a list of available alarms.

Select the video storage device (HDD or SD), month, and year of the desired alarm.

Select the desired alarm from the list of available alarms. Click Save to save the selected alarm to USB storage. Click Play to start playback of the alarm video.

---

## HD5 Series Mobile DVR

---

### **FCC Statement**

Changes or modifications not expressly approved by the party responsible for compliance could void the user's authority to operate the equipment.

This equipment has been tested and found to comply with the limits for a Class B digital device, pursuant to Part 15 of the FCC Rules. These limits are designed to provide reasonable protection against harmful interference in a residential installation. This equipment generates uses and can radiate radio frequency energy and, if not installed and used in accordance with the instructions, may cause harmful interference to radio communications. However, there is no guarantee that interference will not occur in a particular installation. If this equipment does cause harmful interference to radio or television reception, which can be determined by turning the equipment off and on, the user is encouraged to try to correct the interference by one or more of the following measures:

- Reorient or relocate the receiving antenna.
- Increase the separation between the equipment and receiver.
- Connect the equipment into an outlet on a circuit different from that to which the receiver is connected.
- Consult the dealer or an experienced radio/TV technician for help

This device complies with part 15 of the FCC rules. Operation is subject to the following two conditions (1) this device may not cause harmful interference, and (2) this device must accept any interference received, including interference that may cause undesired operation.